



User guide homematic

August 2019

©2017
eQ-3 AG
Maiburger Straße 29
26789 Leer, Germany

www.eQ-3.com

All rights reserved. Translation from the original version in German. This manual may not be reproduced in any format, either in whole or in part, nor may it be duplicated or edited by electronic, mechanical or chemical means, without the written consent of the publisher.

Typographical and printing errors cannot be excluded. However, the information contained in this manual is reviewed on a regular basis and any necessary corrections will be implemented in the next edition. We accept no liability for technical or typographical errors or the consequences thereof.

All trademarks and industrial property rights are acknowledged.

Changes may be made without prior notice as a result of technical advances. Illustrations and diagrams are provided without obligation. All brand and product names mentioned are used solely to clarify the compatibility of our products with specific products made by other manufacturers and are the property of their respective owners.

Apple, the Apple logo, iPad and iPhone are trademarks, registered by Apple Inc., in the USA and other countries. App Store is a service mark of Apple Inc.

Google, Google Play, Android and other brands are trademarks of Google Inc. / The Android robot is reproduced or modified from work created and shared by Google and used according to terms described in the Creative Commons 3.0 Attribution License.

V6.0 (08/2019)

Table of contents

1	News	6
2	Introduction.....	7
2.1	The eQ-3 group.....	8
3	Wireless Home Control.....	9
3.1	What is a smart home?.....	9
3.2	Comparison of smart home technologies.....	10
3.2.1	Radio transmission	10
3.2.2	Wired BUS technology	11
3.2.3	Powerline.....	12
3.2.4	Summary.....	13
3.3	Wireless range	14
3.3.1	Damping	14
3.3.2	Interferences.....	15
3.3.3	Reflections and interference from radio waves	15
3.4	Information about radio compatibility.....	16
4	Overview of Homematic IP	18
4.1	Application areas	19
4.1.1	Heating and climate control	19
4.1.2	Security and alarms	19
4.1.3	Light and shade.....	19
4.1.4	Weather & the environment	20
4.2	Why Homematic IP is the first choice: Your benefits	21
4.3	Functionality of Homematic IP.....	22
4.4	Homematic IP components.....	24
4.4.1	Homematic IP cloud.....	24
4.4.2	Homematic IP smartphone app	24
4.5	General system and flashing behaviour	25
5	Setting up the Homematic IP System	26
5.1	First steps	26
5.1.1	System requirements.....	26
5.1.2	Download the free app.....	27
5.1.3	Set up your Access Point	27
5.1.4	Register Access Point to the server	28
5.2	Homematic IP app	29
5.2.1	Setup screen	29
5.2.2	Home screen	30
5.2.2.1	Location and weather information	30
5.3	Teaching-in devices.....	32
6	General System Configuration	34
6.1	Main menu	34
6.1.1	Device overview	36
6.1.1.1	Range extension.....	37
6.1.1.2	Overview of symbols.....	39
6.1.1.3	Rename and delete devices.....	40
6.1.2	Device updates.....	40
6.1.2.1	Background Update	40
6.1.2.2	Live Update.....	43
6.1.3	Automation	44
6.1.4	Settings	44
6.1.5	Multi-Access Point management.....	44
6.1.6	Info and support	45
6.1.6.1	User guide	46
6.1.6.2	News.....	46
6.1.6.3	Support.....	46
6.1.6.4	EULA	46
6.1.6.5	Open source licenses.....	47
6.1.6.6	Legal notice.....	47
6.1.6.7	Replacing the Access Point	47
7	Climate Control	48
7.1	The benefits.....	48
7.2	Installation planning.....	48
7.3	Configuring the climate control solution for each room.....	53
7.3.1	Operating modes.....	53
7.3.1.1	Manual operation.....	53
7.3.1.2	Party Mode	54

	7.3.1.3	Holiday mode	54	
7.3.2	Room menu		55	
	7.3.2.1	Configuration.....	56	
	7.3.2.2	Consumption metering	58	
	7.3.2.3	Rename room.....	60	
	7.3.2.4	Delete room.....	60	
7.4	System configuration for the climate control solution.....		61	
7.4.1	Heating and cooling profiles.....		61	
	7.4.1.1	The standard profile	61	
	7.4.1.2	Adjusting the heating profile	62	
7.4.2	Climate control configuration		65	
	7.4.2.1	Eco mode configuration	66	
	7.4.2.2	Optimum start/stop function	67	
	7.4.2.3	Humidity warning.....	67	
	7.4.2.4	Whisper mode for radiator thermostats.....	68	
	7.4.2.5	Heating failure alert	68	
7.5	Heating system control and hot water supply with HmIP-MIOB /HmIP-WHS2		70	
7.5.1	Application example 1: Heat demand control of the boiler		70	
	7.5.1.1	Heating system control for heat demand - without leading room	71	
	7.5.1.2	Heating system control for heat demand – with leading room.....	72	
	7.5.1.3	Control of the cooling mode of the heating system – without leading room	74	
7.5.2	Application example 2: Hot water supply.....		75	
	7.5.2.1	Hot water profile.....	75	
	7.5.2.2	Controlling the hot water supply via a wall-mount remote control	77	
7.6	Floor heating control.....		79	
7.6.1	Options for controlling the floor heating system		80	
7.6.2	Set-up and configuration via wall thermostats (stand-alone without Access Point)		81	
	7.6.2.1	Teaching-in	81	
	7.6.2.2	Application of several floor heating actuators.....	81	
	7.6.2.3	Communication test	82	
	7.6.2.4	Configuration via Wall Thermostat	82	
7.6.3	Set-up and configuration via the Homematic IP app.....		88	
	7.6.3.1	Teaching-in of the wall thermostat.....	88	
	7.6.3.2	Teaching-in the floor heating actuator	89	
	7.6.3.3	Definition of terms for floor heating control.....	90	
7.6.4	Application examples		92	
	7.6.4.1	Application example 1: Floor heating control.....	92	
	7.6.4.2	Application example 2: Floor heating and heating pump control	94	
	7.6.4.3	Application example 3: Floor heating, boiler and dehumidifier control.....	96	
	7.6.4.4	Application example 4: Floor heating, heating pump, boiler and dehumidifier control	98	
	7.6.4.5	Application example 5: Floor heating and heating pump control with switching from heating to cooling mode..	100	
	7.6.4.6	Cooling mode configuration.....	102	
	7.6.4.7	Application example 6: Floor heating and heating pump control with switching between heating and cooling via external switch	105	
	7.6.4.8	Application example 7: Floor heating and heating pump control with switching between heating and cooling mode as well as humidity limit.....	108	
	7.6.4.9	Application example 8: Floor heating and heating pump control with temperature limit	111	
	7.6.4.10	Application example 9: Floor heating and heating pump control with external clock for temperature reduction mode	114	
	7.6.4.11	Application example 10: Floor heating and heating pump control with energy saving for cooling mode	117	
8	Security.....		120	
8.1	The benefits		120	
8.2	Installation planning.....		121	
	8.2.1	Configuration of the Homematic IP Water Sensor (HmIP-SWD)	124	
8.3	Alarm messages in the app		126	
8.4	Activate alarm mode.....		129	
	8.4.1	Security information in the menu item "Security"	130	
8.5	Configuration of the security solution.....		132	
	8.5.1	Alarm protocol	133	
	8.5.2	Alarm configuration	133	
	8.5.3	Light configuration.....	137	
		8.5.3.1	Alarm light	137
		8.5.3.2	Panic light.....	137
		8.5.3.3	Coming home light	138
	8.5.4	Presence mode	139	
8.6	Integration of Smartfrog cameras into the Homematic IP system.....		139	
9	Shutter Control		141	
9.1	The benefits		141	
9.2	Installation planning.....		142	
9.3	Starting operation of shutter and blind actuators		144	
	9.3.1	Calibration run.....	144	
		9.3.1.1	Automatic calibration run (for HmIP-BROLL and HmIP-BBL).....	144

9.3.1.2	Manual calibration run.....	145
9.3.2	Device settings	147
9.3.2.1	Assignment.....	147
9.3.2.2	Movement times	147
9.3.2.3	Slats movement time	147
9.3.2.4	Delay for changing the movement direction	147
9.4	Shutter groups	147
9.4.2.1	Creating shutter groups.....	147
9.4.2.2	Manual control of shutter elements in groups.....	149
9.5	Shutter profiles.....	150
9.5.2.1	Adjusting the time profile	150
9.6	Shutter configuration	152
9.6.1	Lockout protection.....	153
9.6.2	Storm protection	154
9.6.3	Heat protection.....	155
9.6.4	Escape function	157
10	Light Control	158
10.1	Installation planning.....	158
10.2	Configuration of the light solution	158
10.2.1	Switching groups.....	159
10.2.1.1	Creating a switching group	159
10.2.1.2	Rename or delete switching groups.....	161
10.2.1.3	Selecting the dimming value.....	161
10.2.1.4	Defining the switch-on time	161
10.2.2	Switching profiles	162
10.2.2.1	Creating switching profiles.....	162
10.2.2.2	Additional information for switching with motion detectors/presence sensors	163
10.2.3	On/off control of groups in the homescreen.....	164
10.2.4	On/off control in the menu item "Light"	164
11	Groups, Time Profiles and Automation	166
11.1	Setting up automations.....	166
11.2	Activation and deactivation of automations.....	167
11.3	Application example: Night light in the darkness	167
11.4	Application example: Signal for bathroom occupied/free	170
12	Voice Control for Homematic IP	172
12.1	Comfortable voice control for your smart home.....	172
12.2	Voice control with Amazon Alexa.....	174
12.2.1	Setting up Amazon Alexa	174
12.2.1.1	Connecting your Homematic IP smart home system with Alexa	174
12.2.1.2	General information about Alexa and Homematic IP.....	177
12.2.1.3	Alexa update of the device list.....	178
12.2.1.4	Devices and functions supported by Amazon Alexa.....	179
12.2.1.5	Voice command examples	180
12.2.1.6	Alexa smart home device groups.....	180
12.2.2	Alexa routines	182
12.2.2.1	Creating routines	182
12.2.2.2	Deleting the connection between Homematic IP and Alexa.....	185
12.3	Voice control with Google Assistant/Home	185
12.3.1	Setting up Google Home	185
12.3.1.1	General information about Google and Homematic IP.....	188
12.3.1.2	Voice command examples	188
12.3.1.3	Devices and functions supported by Google	189
12.3.1.4	Google update of the device list	189
12.4	Voice control with Google Assistant.....	190
12.5	Voice control during active alarm mode.....	190
13	Integration into Homematic Systems	192
14	Appendix	195
14.1	Function overview for active and inactive Internet connection	195
14.2	Troubleshooting check-list	197
14.3	Homematic IP radio protocol and receive modes.....	199
14.3.1	Device software update (OTAU)	200
14.3.2	Duty cycle	200
14.3.3	Lazy config	201
14.4	Overview flashing behaviour of Homematic IP devices	202
14.5	Glossary.....	203

1 NEWS

Release August 2019

- [Differentiation of alarm notifications \(intrusion and hazard alarms\)](#)
- [Separate configuration of alarm sirens – indoor and outdoor](#)

Release February 2019:

- [Individual sounds for alarm messages](#)
- [Air humidity warning](#)
- [Whisper mode for radiator thermostats](#)
- [Heating failure alert](#)

Release January 2019:

- *Voice Control for Homematic IP*
- *Optimum start/stop function*
- *Heating system control and hot water supply with HmIP-MIOB /HmIP-WHS2*
- Implementation of the Homematic IP Contact Interface flush-mount – 1 channel

Release May/June 2018:

- New devices
 - HmIP-SLO
 - HmIP-BSL
- Description of the optimum start/stop function for floor heating systems

Release March 2018:

- Description of extended security configuration
- Description of weather sensor functions
- Additional information about range extension and device updates
- General adjustments and updates (e.g. floor heating control, voice control)

2 INTRODUCTION

A *smart home* describes a house or flat that is equipped with an intelligent system that offers automation, control, regulation and monitoring of recurring functional processes and applications within the own four walls. Modern smart home solutions offer remote access, e.g. via smartphone or tablet and cover a wide range of application areas. These include climate and access control, security and alarm functions as well as light control or weather information and time or climate-dependent regulation of smart home functionalities.

Homematic IP is the next generation of the successful smart home system Homematic by eQ-3.

The Homematic IP User Guide offers comprehensive information about the technology, installation, start-up and functionality of Homematic IP. In addition, you will find numerous answers to questions for everyone, who is in home automation and Homematic IP in general.

You will also receive basic information about smart home and radio technology, offering useful tips for planning and ideal operation of the Homematic IP system.

2.1 The eQ-3 group

In over 35 years, the ELV-/eQ-3 group has developed from a technology pioneer to one of the European market leaders in smart home.

eQ-3 stands for innovation across a broad spectrum of technologies which, when combined with one another, represent a major leap in customer-oriented solutions. In the smart home area, there are numerous examples in wireless technology and mechatronics - amongst others in electronic radiator thermostats. The eQ-3 Group has core expertise in battery operation, as well as in communication between two or more battery-operated devices.

With its smart home products, eQ-3 is a market leader and, by integrating IPv6 into mass-market home automation products, the company is already turning the oft-quoted vision of the Internet of Things (IoT) into a reality. With more than 1,000 employees, the ELV/eQ-3 Group is one of the largest and fastest-growing employers in Germany's East Frisia region.



Development

eQ-3 realises market requirements particularly fast, using state-of-the-art technology and best practices while maintaining close contact with the market and customers. With more than 80 employees, the R&D team is one of the biggest and most experienced in the field of smart home in Europe, so even very demanding projects are in safe hands.

Production and tool making

By carrying out our development work in Germany and manufacturing in the Group's wholly-owned plant in Zhuhai, southern China, eQ-3 provides the ideal combination of high-quality German engineering and low manufacturing costs. With an extensive vertical range of manufacture, from tool manufacture, plastic injection moulding and clean-room painting, equipping, modern wave soldering, and assembly and testing to chip bonding directly on the PCB, eQ-3 can realise manufacturing batches of hundreds to hundreds of thousands of products.

Quality

The pledge to provide maximum process quality is a guideline that runs through all company areas at eQ-3. All eQ-3 products are "Developed in Germany", and strictly follow all of the relevant safety standards. Our plant is certified in accordance with ISO 9001:2000 and the international environmental management standard ISO 14001 as well as standards for social responsibility. Furthermore, manufacturing is subjected to regular plant inspection audits for certification by VDE, VdS, TÜV Rheinland LGA and UL.

3 WIRELESS HOME CONTROL

3.1 What is a smart home?

A *smart home* offers automation of recurring day-to-day operations and tasks in houses or flats: While using an appropriate system, different (technical) devices and functionalities can be connected throughout one household, offering most comfortable control and automation of recurring tasks.

An intelligent home control system makes your house a smart home – literally an “intelligent house”. It increases the security level in your living environment, helps to save energy and increases the personal living comfort. A climate control solution for heating control reduces your heating costs by up to 30 percent without any loss of comfort, whilst offering considerable cost savings immediately. With comfortable light control, a cosy atmosphere is created at the push of a button. Alarm systems, automated shutter control, connected door and window contacts, smoke alarms and motion sensors protect your home as well.

To enable control also while being out of the house, modern home automation systems are connected to the Internet. With an active Internet connection, it is possible to access the system, control devices or request information about devices or states from a PC or with a smartphone app at any time and almost every place.

On the one hand, a main requirement to a home control system is the security counteracting unauthorised access from the outside. On the other hand, the used technology has to operate reliably. Finally, the system must offer intuitive and user-friendly installation and operation. Also, easy expansion options are an important factor. With Homematic IP, the new and optimised smart home product range, eQ-3 has developed a system that fulfils all these requirements.

3.2 Comparison of smart home technologies

For the transmission of data in the smart home area, i.e. communication between single components within buildings, the following technologies are primarily used nowadays:

- radio communication,
- wired BUS systems and
- Powerline adapters (via current distribution in the house).

Every system has its specific advantages and disadvantages. Which system to choose depends, for example, on the intended purpose of either installing the smart home system in a new building or, alternatively, of retrofitting a home. Furthermore, there are various parameters in relation to the system that should be considered before reaching a decision.

The following provides information about the three most important system technologies and shows their advantages and disadvantages.

3.2.1 Radio transmission

Radio-based systems use wireless radio connections for controlling and communicating between the integrated devices.

Pros:

- **Flexibility:**
One of the main advantages of a radio-based system is the almost unlimited flexibility. As no cables have to be laid, these systems can also be retrofitted without great effort and, if required, can be easily removed. If the living situation changes, the existing system can be easily adjusted. In addition, wireless systems are ideal if planning to combine many different components with each other. At the same time, multiple actions can be triggered and entire scenarios are realised at the push of a button. For example, upon returning home by car and pushing a button on the key-ring remote control, the garage door opens, the light intensity of the garden lights is increased and the way to the entrance is illuminated. While approaching the house, the radiator thermostat in the living room is already adjusted to the individual comfort temperature.
- **Security:**
There are great differences between the radio systems in terms of security aspects. Due to encrypted authorization control of radio commands (authentication), unauthorised interference from the outside is almost impossible with Homematic and Homematic IP.
- **Low energy consumption:**
Wireless devices are characterized by low stand-by consumption.
- **Easy to install:**
You can easily install battery-operated wireless devices by yourself.

Cons:

- **Interferences caused by other systems:**
Depending on the radio frequency used, the communication between the wireless devices can be interfered by other radio systems. This becomes particularly difficult, if the radio system works on the same frequency like WLAN routers, Bluetooth devices or video and audio streaming systems. Homematic IP works on a frequency band that is insensitive to influences by these systems.
- **Wireless range:**
The wireless range of devices is limited. But, however, it is sufficient for most situations in private households. If the wireless range may once be insufficient, it can be extended using wireless routers with Homematic IP.
- **Changing batteries:**
Depending on the device and operational frequency, the batteries of battery operated devices need to be replaced in different time intervals (1-5 years). In many case, battery operation is less expensive than stand-by operation of e.g. Powerline adapters.

3.2.2 Wired BUS technology

For so-called 'wired systems', wired BUS components are used. These devices communicate in a BUS system via cable or plug connector. They are usually installed via DIN rail into electrical distribution boards or as flush-mounted devices into switch boxes or junction boxes, especially in new or commercial buildings.

Pros:

- **Reliability:**
Wired devices are more or less insensitive to interferences. Furthermore, the devices are very reliable and offer low-maintenance operation as power is supplied by a power supply unit in the installation.

Cons:

- **Extension of the system:**
As the communication between wired components is performed via cable connections, the extension of existing systems is more complex. For example, cables have to be run to the distribution board for an additional push-button.
- **Installation:**
Another disadvantage that arises from the installation site. Mounting and troubleshooting can only be performed by an electrician.
- **Limited product portfolio:**
The product range is limited to mains-operated devices. This is why the application fields are mainly limited to network solutions within buildings. Controlling of other functional areas such as conventional radiators using radiator thermostats is not possible in this way.



In addition to the radio devices, Homematic IP now offers a bus variant of the smart home system, the product line Homematic IP Wired All Homematic IP devices, whether wireless or wired, are compatible with each other via the CCU3 and can be combined in one system. This makes Homematic IP the ideal solution for a smart home.

3.2.3 Powerline

Powerline uses the existing infrastructure available in every household: the domestic power supply system. Furthermore, there are systems using coaxial cables that have already been installed (antenna cable for radio or television reception) for the transmission of data. Powerline solutions are ideal if laying cables is too complex or a wireless solution can hardly be installed due to difficult constructional prerequisites.

Pros:

- **High data rate:**
One advantage is that Powerline adapters offer a high data rate which is ideal for LAN applications such as video streaming.
- **Range:**
The range which is the maximum line length between the adapters, is up to 300 meters for new devices.

Cons:

- **Installation:**
When using adapters without integrated sockets, the sockets in the house are occupied by Powerline devices.
- **Limited product portfolio:**
The product range is limited to mains-operated devices. This is why the application fields are mainly limited to network solutions within buildings. Controlling other functional areas such as conventional radiators using radiator thermostats is not possible in this way.
- **Sources of interference:**
Furthermore, devices that are connected to the power supply system can reduce the signal range and cause interference with the communication. This especially applies to devices with electrical motors like vacuum cleaners. Powerline networks also react sensitively to dimmers or ballasts.

3.2.4 Summary

Based on the numerous advantages, eQ-3 has decided to choose a wireless system for an ideal smart home solution.

The modern and efficient system Homematic IP

1. is very reliable and robust,
2. can be easily operated and set-up by anyone,
3. is future-proof and ideally prepared for the Internet of Things thanks to IPv6,
4. offers a high wireless range between 150 and 400 m (depending on the device),
5. uses the radio frequencies 868.3 MHz and 869.525 MHz for communication and is therefore interference-proof against WLAN, Bluetooth, radio technology and video streaming systems,
6. offers great flexibility in terms of retrofitting and extension possibilities,
7. fulfils highest security requirements thanks to AES encrypted authorization control,
8. with server location in Germany, operated in accordance with the strict German data protection regulations,
9. does not require any personal data and
10. offers easy integration of many different devices into the system.

**Simple installation:**

No specialist knowledge or other special skills are required for the installation.

Simple configuration:

The entire solution is intuitively set up via smartphone app for iOS and Android. Configuration of single devices is performed by the Homematic IP software.

Simple operation:

The devices are operated room-by-room via the app or on the device itself.

3.3 Wireless range

eQ-3 benefits from more than 30 years of experience in the field of wireless technology for smart home applications. Homematic IP is based on the same particularly effective and robust wireless technology like Homematic and has proven its market success with millions of devices.

The wireless range of Homematic IP exceeds the standard requirements of a typical installation. Depending on the device type, a wireless range between 150 and 400 meters in the open air can be reached. Experience shows that in less than 1 % of installations repeaters are used to extend the wireless range.

Radio waves behave in a similar way as sound waves. They can pass through walls and spread out in all directions. Similar to the volume of sound, the energy of radio waves decreases with distance. Thus, the range of radio waves is limited.

In practice, there are factors that can influence the radio signal in a positive and negative way, compared to the range in the open air. There are two main reasons for the reduction of radio signals: **damping** and **interferences**.



For further information on the extension of the radio range using the Homematic IP Pluggable Switch (HmIP-PS) or the Homematic IP Pluggable Switch and Meter (HmIP-PSM), please refer to section *"Range extension"* on page 37.

3.3.1 Damping

Damping is defined by the installation conditions on site (e.g. a wall) and can hardly be influenced. Thus, under certain circumstances, the building materials can reduce the strength of radio signals in such way that they reach the receiver damped, incorrectly or not at all.

For the installation position of wireless devices it should be taken into account that dampening values are above average when it comes to materials containing metals. This does not relate to building materials such as insulating materials with metal foils, but does relate to metal doors or large electrical appliances such as washing machines, for example. Metal bodies can have both dampening as well as amplifying effects to the radio signal.

Particularly in rental flats, it is often difficult to find out about the walls' construction. Therefore, it is recommended to install the transmitter and receiver only temporarily for testing the quality of the signal transmission.

With an open air range of 150 to 400 meters, Homematic IP can usually be used in private buildings without any transmission errors.

The following table gives an overview of the damping effects of single building materials:

Building material	Damping
Pumice stone/autoclaved aerated concrete	●○○○
Gypsum and gypsum plasterboard	●○○○
Uncoated glass	●○○○
Metallised glass	●●○○
Wood	●○○○
Metal grille (e.g. in plaster)	●●●●
Press boards	○○○○
Stone slabs	●○○○
Brick	●○○○

3.3.2 Interferences

Interferences are caused by electrical devices in households and negatively influence the signal quality of radio components. These interferences are substantially reduced by keeping a distance as large as possible between the radio components and those potential sources of interference.

This applies in particular to objects that emit radio waves:

- computers
- radio speakers and radio headsets
- audio and video systems
- alarm systems
- mobile phones and cordless phones
- microwave ovens
- electronic ballasts for fluorescent lamps
- audio baby-monitors

Different radio systems that are used for smart home applications communicate on the 2.4 GHz frequency band. Examples are systems that are based on Bluetooth Smart, WLAN and Zigbee. Homematic IP is not influenced by interference from such systems, as it works in another frequency band than e.g. Bluetooth, WiFi, video and audio streaming systems or DECT phones.

3.3.3 Reflections and interference from radio waves

Radio waves are redirected (reflected) on all surfaces. This offers the advantage that signals reach the receiver even if it is located in the radio shadow. Radio shadows occur if radio components are not available directly, in a straight line, e.g. because metal objects dampen the radio signal. A temporary test setup should be used to make sure that the reflection is sufficient under certain circumstances.

Interference is a phenomenon within a radio system installed in the house. It occurs, if the antenna receives both direct as well as reflected waves or radio wave of other transmitters. Due

to this interference effect, there may be a damping or overlapping of the radio signals. In many cases it can help to slightly change the position of the components.

3.4 Information about radio compatibility

With Homematic IP as a radio-based system, it is helpful to address the question if health risks might occur due to radio wave impact.

There are no confirmed statements about health effects caused by radio systems for home automation. With such low transmission power, it is not possible to measure direct effects. Results of a long-term study are not yet available. Therefore, it makes sense to compare it with widespread radio techniques as used for WiFi and mobile networks as well as for cordless DECT telephones.

During the evaluation of the biological compatibility, a series of different factors like the transmission power, the transmission duration and in particular the distance of the body to the radio devices play a role. All these factors influence the level of radiated energy that actually reaches the body in typical usage situations (exposure level) into the body. Radio systems should in any case comply with all legal requirements related to security and environment.

Transmission power and duration

In direct comparison, Homematic IP devices work with much lower transmission power. According to statements from the Federal Network Agency, a transmission capacity of up to 100 mW for WiFi devices is allowed, while devices in mobile networks may reach a maximum power of more than one watt¹.

On the other hand, Homematic IP devices usually operate with a transmission power of 10 mW. This already proves a typical difference by a factor of 20 in the transmission power and thus regarding the potential exposure.

The transmission duration of radio telegrams for the communication between Homematic IP devices takes place in a range of milliseconds and is usually between 10 to 30 milliseconds. Most of the time, the devices are in "sleep mode" and are only active if a status message is transmitted. If, for example, the room temperature is set via the wall thermostat, it 'wakes up' the connected radiator thermostats and transmits the new setpoint temperature. Compared to WiFi, mobile and DECT networks, where almost permanent radio activity is given, the transmission of Homematic IP is very infrequent. Furthermore, a maximum transmission time of 36 seconds per hour and device defined by law is set for the frequency band used for Homematic IP. In a normal installation, this is not reached at all.

Regarding the transmission power and duration, the following comparison can be made: A typical conversation via mobile phone takes approximately 5 minutes with a permanent transmission power of at least 300 mW. In comparison, a Homematic IP actuator transmits approximately 1 second per day at 10 mW power in total.

In other words: In order to reach the radio pollution of a five-minute conversation via mobile phone, one Homematic IP actuator would have to be switched on daily for more than 25 years.

¹ Federal Network Agency: "Service Booklet WLAN" at: https://www.bundesnetzagentur.de/SharedDocs/Downloads/DE/Allgemeines/Bundesnetzagentur/Publikationen/service/WLAN.pdf?__blob=publicationFile&v=9 (Januar 2018)

Furthermore, the actuator would have to be situated in the immediate vicinity of the body (like a mobile phone at the ear).

Legal requirements

All Homematic IP devices are, in addition, marked with the CE sign, indicating that the product has been tested and comply with the legal requirements of the EU guaranteeing health protection, security and environmental protection before they are placed on the market.

The eQ-3 group has received a statement from the internationally renowned test laboratory Phoenix Testlab, proving the compliance of Homematic IP devices with the European regulation EN 62479. In detail, the regulation implies the "compliance of low power electronic and electrical equipment with the basic restrictions related to human exposure to electromagnetic fields (10 MHz to 300 GHz)"². According to this declaration, the Homematic IP radio modules are far below the "radiation" limits defined by law.

It can, however, be assumed, that no health risks are caused by the radio technology used within the Homematic IP system. This also applies to persons with hearing aids and cardiac pacemakers – another aspect that has been proved during tests of our own department for electromagnetic compatibility (EMV).

4 OVERVIEW OF HOMEMATIC IP

Homematic IP is the next generation of the successful smart home system Homematic by eQ-3. The constantly growing product range of Homematic IP includes devices for climate control, security, weather, light and shutter control applications as well as various accessory components. The climate control devices offer demand-based room-by-room control of radiators throughout the entire house, enabling users to save up to 30 % on their energy costs. In addition, floor heating systems can efficiently be controlled with Homematic IP products. No movement goes unnoticed with the security components. Users are informed whenever windows and doors are opened. One look at the app is enough to find out that everything is all right at home. Comfort is enhanced with switching and dimming actuators for light control as well as products for automation of shutters and blinds. All Homematic IP devices for brand switches can be easily integrated into the design of existing switch series using our adapters. The Homematic IP Weather Sensors do not only offer the possibility of recording and evaluating measured data. Furthermore, in combination with products of other areas, it is for example possible to adjust the smart home to current weather conditions, e.g. by moving up the shutters in case of strong wind.

For operation, the Homematic IP Access Point in connection with the Homematic IP app (no recurring costs), the Homematic Central Control Unit CCU2/CCU3 or an appropriate partner solution is required. Once installed, the system can be controlled comfortably via app, remote control or wall-mounted push-button. In addition, the combination of almost all devices and conditions of various application areas is possible. Therefore, the Homematic IP app offers pre-programmed functionalities as well as the configuration of individual automation rules. There are virtually no limits to the users' creative leeway. Another benefit is offered by controlling the system using voice control services like Amazon Alexa and Google.

Single devices are configured by the Homematic IP cloud service, which is run exclusively on servers located in Germany and therefore complies with European and German data protection guidelines. All data stored in the Homematic IP cloud is completely anonymous. However, it does not allow any conclusion about the user's identity and the individual usage behaviour. Furthermore, all communication between the Access Point, cloud and app is encrypted. As neither during nor after installation of the app you will need to provide private data such as name, email address or mobile phone number, your anonymity is protected 100%.

Homematic IP builds on the strengths of Homematic, implements IPv6 – the next generation Internet protocol – in each device and therefore offers a solution tailored to the Internet of Things (IoT). Thanks to the open platform, the solution can be flexibly expanded at any time - Via the Homematic Central Control Unit CCU2/CCU3 all Homematic IP devices can also be integrated into an existing Homematic system.

As the devices communicate via radio, they can be retrofitted into houses really easily. All products communicate via the robust and reliable 868 MHz Homematic IP wireless protocol. This means that there is no interference whatsoever from WLAN, Bluetooth or other radio standards operating within the 2.4 GHz frequency band.

4.1 Application areas

4.1.1 Heating and climate control

Homematic IP offers demand-based control of radiators room-by-room in the entire house, enabling increased living comfort and energy savings of up to 30 %. The Homematic IP Window / Door Contact detects open windows and doors and automatically turns down the heating during ventilation. In addition, efficient floor heating control that offers operation via app can be realised with Homematic IP. The system detects the required heat for single rooms and - unlike conventional heating circuit control systems - intelligently circulates the hot water into multiple heating zones. This provides load balancing and efficient energy distribution thanks to the continuous flow of heating water. The room temperature is regulated via radiator thermostats, an installed wall thermostat or simply via app. Also, individual heating profiles can be created with Homematic IP. Afterwards, your heating is controlled automatically and makes the everyday life easier. However, you can still react flexibly to changed conditions and adjust the desired temperature according to your needs.

4.1.2 Security and alarms

No movement goes unnoticed with Homematic IP security components. Our security and alarm products increase the protection against break-ins and the sense of security inside the own four walls.

In alarm mode, users are informed whenever windows and doors are opened. Motion detectors offer reliable monitoring for inside and outside areas while sirens and smoke alarms trigger an alarm in case of break-ins or fire.

Just a quick glance at the app is all it takes to see that everything is as it should be at home. Even from afar, there is always a way to find out if doors or windows have been left open.

The alarm mode can be easily activated via app or Homematic IP Key Ring Remote Control. For example, if the presence mode is activated, the system triggers an alarm as soon as windows or doors are opened unauthorised. During activated "absence mode", also sensors for indoor areas like the motion detector are included. In case of alarm, an audio signal can be triggered via the Homematic IP Siren or the Smoke Alarm and a push notification is sent to all connected smartphones. The alarm protocol provides an overview of all activities in your home at any time.

4.1.3 Light and shade

Comfortable switching and dimming of lights creates a sense of well-being at your home. Thus, a comfortable atmosphere for TV evenings is created via the app as the ceiling light are dimmed to a desired brightness level while the floor lamp is switched on. Also, the sense of security is increased with an illuminated driveway or house façade in the evening. Homematic IP products for light control are easily integrated into the installations of a home since existing frames and rockers can continue to be used.

Shutters and blinds darken rooms, create a sense of privacy and increase security. With shutter and blind actuators, the window coverings are set up in just a few single steps using the Homematic IP app. Afterwards, they can be raised or lowered automatically.

Actuators are controlled comfortably via individual week profiles, and can also be connected to the sunrise and sunset. Furthermore, active shutters and blinds make the house look inhabited even if not at home, thus actively increasing the security. Another advantage: In case of increased room temperatures due to strong sunlight, shutters or blinds are automatically lowered to prevent the room from heating up.

The Homematic IP Blind Actuators also allow exact adjustment of the slats position of exterior and interior blinds. If required, also the integration of awnings into the smart home is possible with Homematic IP. The automatic storm protection avoids damages to shutters, interior blinds and awnings during unfavourable weather conditions and thus raises or lowers the window coverings.

4.1.4 Weather & the environment

With the weather sensors, the Homematic IP smart home system is automatically adjusted to current weather conditions. In connection with other Homematic IP devices, the sensors automatically trigger commands for moving awnings, interior blinds or shutters up and down in case of certain weather conditions, providing active protection of the house. Users have almost unlimited possibilities for creating individual rules. For example, in case of strong sunlight and inactive security mode, the awning is automatically extended to 80 % or with a previously defined rainfall volume, the drainage pump is activated for a certain period of time.

4.2 Why Homematic IP is the first choice: Your benefits

✓ **Simplicity**

The entire solution can be intuitively set up and comfortably controlled via smartphone app. Single devices are configured by the Homematic IP cloud service. As the devices communicate via radio, they are retrofitted into houses.

✓ **Interference immunity**

Homematic IP is based on the 868 MHz radio band. There is no interference whatsoever from WLAN, Bluetooth, video streaming or other users of 2.4 GHz.

✓ **Superior range**

Reliable communication between Homematic IP devices works even over a distance of a few 100 meters. Even for remote places there is no need to worry about the functionality of the chosen smart home solution.

✓ **Uncompromising security**

During installation of the system, the communication of Homematic IP is secure and cannot be manipulated. During operation, all radio packages are encrypted and authenticated. Reading, changing or repeating data or other kind of attacks are impossible. Similar to online banking, the established AES-128 and CCM standards are used.

✓ **Battery operation**

Homematic IP focusses on battery operated devices in order to enable smart home installations also in existing buildings. The products can be easily screwed on to radiators or stuck to walls. Thanks to the low energy consumption of the devices, batteries usually only need to be replaced every two years, or even less frequently.

✓ **Reliability**

All Homematic IP products offer permanent bidirectional communication. Every radio command is confirmed by the addressed device. The current status of all devices can be clearly shown.

✓ **Privacy policy**

For setting up the system, no personal data has to be provided. The Homematic IP cloud is only operated on servers located in Germany. The operation does therefore comply with European and German privacy policies.

✓ **Experience**

Homematic IP is the smart home solution and technology by eQ-3 AG. Based on long-term experience in developing wireless smart home products, eQ-3 has established as European market leader*³ in home control.

3 * According to Berg-Insight (2018). Installed base of whole home devices

4.3 Functionality of Homematic IP

The Homematic IP system basically consists of the following components:

- Homematic IP Access Point
- Homematic IP cloud
- free Homematic IP smartphone app
- single wireless components of the corresponding Homematic IP solution.

In connection with a router, the Homematic IP Access Point is the interface that connects your wireless Homematic IP components with the Internet.

The Homematic IP cloud takes over communication between the free smartphone app and the Homematic IP Access Point as well as saving and managing data, e.g. information about which devices have been connected, which devices belong to a group in a room or details about their configuration.



All data stored in the Homematic IP cloud is completely anonymous. However, it does not allow any conclusion about the user's identity and the individual usage behaviour. Identifying a Homematic IP user is only possible as part of a criminal prosecution or based on a court order.

The Homematic IP smartphone app, together with the cloud and the Access Point, enable the setup, programming and controlling of your smart home system. Scanning via the app makes integration of single Homematic IP components very easy by simply scanning the device QR code. To make sure that the system continues to run also in case of Internet failure, all necessary connections between the devices are determined by the Homematic IP cloud service and created automatically. Thanks to direct connections between the devices it is ensured that operation still continues also during an Internet failure.



All communication between the Access Point, cloud and app is encrypted. Neither during nor after installation of the app, you will need to provide private data such as name, email address or mobile phone number. Your anonymity is protected 100%.

All Homematic IP devices can be integrated into existing Homematic systems via the Homematic Central Control Unit CCU2/CCU3. In this case it is possible to configure and operate the devices via a web interface on a PC. When using a CCU2/CCU3, the data is stored locally in the Central Control Unit and not in the *cloud*.



Figure 1: Function graphic of Homematic IP components

4.4 Homematic IP components

The devices of the Homematic IP system are characterised by a smart, uniform product design. The main aspects have been ergonomics and usability. This also applies to each single device: the design and functional elements have been reduced to the essentials, which significantly simplifies the operation.



Detailed information about the single Homematic IP devices can be found in the datasheets of the Homematic IP devices, available for download at www.eQ-3.com.

4.4.1 Homematic IP cloud

The **Homematic IP cloud** enables communication between the app and the Access Point as well as saving and managing of system relevant data. This implies e.g. information, which devices have been taught-in or connected, as well as details about the configuration.

All communication between the Access Point, *cloud* and app is encrypted. No private data is necessary when using the smartphone app and the Homematic IP cloud. The system is easily put into operation by scanning a QR code and pressing the system button of the Access Point, making installation secure and anonymous.

4.4.2 Homematic IP smartphone app

Via the **Homematic IP smartphone app** you can easily set-up your smart home solution. The app offers step-by-step guidance through the entire installation process. All necessary links between the devices are established automatically.

After set-up, the app takes over the function of a central control unit, enabling you to control and configure your entire Homematic IP system. In addition, the app informs you about the status of your devices at all times.



No matter the location:

With the free smartphone app, everything is in sight whenever needed. Control your smart home at any time from any place.

Simply comfortable.

4.5 General system and flashing behaviour

Almost all Homematic IP devices are equipped with a system button with the Homematic IP symbol.



This enables execution of system functions, for example restoring of factory settings (reset) or restart of the teach-in procedure (connection of devices). For single-channel actuators like the Homematic IP Pluggable Switch it is also possible to change switching status (on/off) of the device via the system button.

In its function as system button, it is used for reset as well as for manual teaching-in of Homematic IP devices.

In its function as device LED it works as status display as well as indication of system states using different flashing sequences, e.g. for successful transmission of a new setpoint temperature.

Teaching-in (connection of devices):

After inserting the batteries or switching on the power supply, the teach-in mode of the Homematic IP devices is started automatically. The device LED flashes orange every 10 seconds - as long as the teach-in partner has been found or the teach-in time of 3 minutes has passed. The teach-in mode can be started again by pressing the system button one time shortly.

Normal operation:

In normal operation, command transmission (e.g. at the wall-mount remote control) is displayed by an orange flashing signal. If the command has been successfully executed by the receiver, it will be displayed by the device LED shortly flashing green. If the transmission failed, it will be displayed by the device LED shortly flashing red.

Battery status:

If the battery load of a Homematic IP device is low, it will be indicated in advance. In this case, the device LED shortly lights up orange once after successful or failed transmission of a radio command.

You will find an overview about all flashing signals of Homematic IP devices in the appendix *"Overview flashing behaviour of Homematic IP devices"* on page 202. Furthermore, each device has a device-specific flashing behaviour. This especially applies for the Access Point. For further information, please refer to the manual of the corresponding device.

5 SETTING UP THE HOMEOMATIC IP SYSTEM

5.1 First steps

You can easily and intuitively set up your Homematic IP system using the smartphone app "Homematic IP". This has been developed exclusively for the configuration and control of the Homematic IP smart home system.

In just a few steps, your system is already installed:

- ✓ Check the system requirements.
- ✓ Install the free smartphone app.
- ✓ Set up the Access Point.
- ✓ Register the Access Point to the server.
- ✓ Finished!

You can now configure your system and connect additional devices. You will find further information about the single set-up steps below:

5.1.1 System requirements

For setting up the system, you will need the following components:

- Homematic IP Access Point
- Smartphone (Android (version 5 and higher) or iOS (version 8.0 and higher))
- Router with Internet connection

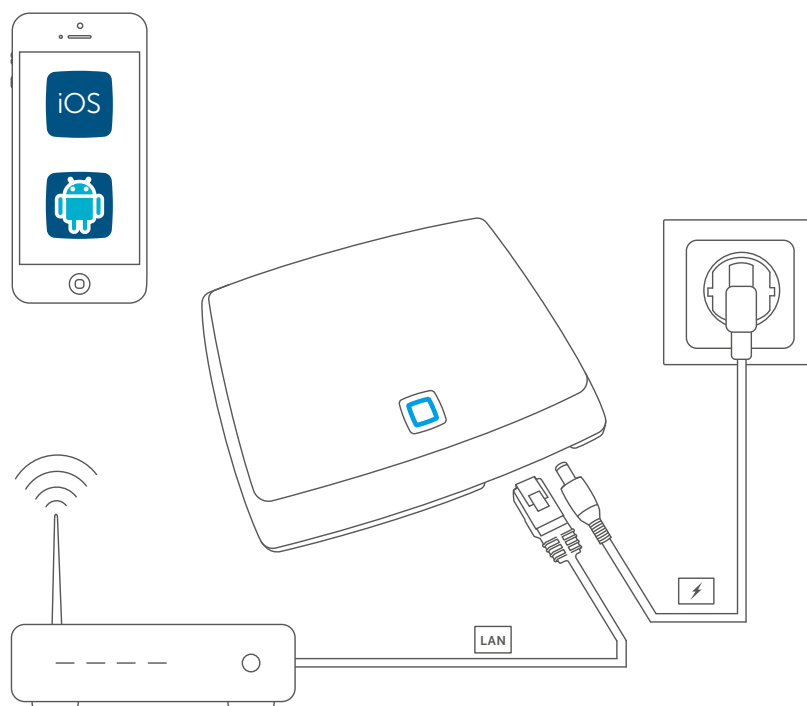

5.1.2 Download the free app

The free app can be downloaded in the Google Play Store (for Android smartphones) or in the iTunes store (for iPhones) directly to your smartphone.

- Start the Homematic IP app on your smartphone.
- Confirm the Terms and Conditions as well as the Privacy Notice via the button "Confirm" (Android) or "Accept" (iOS).





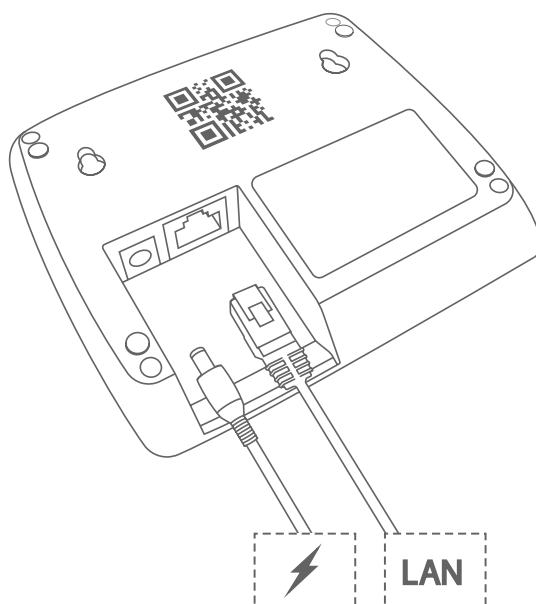

5.1.3 Set up your Access Point

- The menu item "Set up your Access Point" is displayed.
- Follow the instructions and connect your Homematic IP Access Point using the supplied network cable to your router.
- Provide power supply for your Access Point using the supplied plug-in mains adapter.



As soon as power is supplied, the Access Point establishes a connection to the server. Different flashing sequences of the device LED inform the user during set-up about the current status of the Access Point. If an active Internet connection is established, the flashing sequence is usually as follows:

Flashing code	Meaning	Solution	
	Permanent orange lighting	Homematic IP Access Point starts up	Please wait until the device has started and observe the subsequent flashing behaviour.
	Fast blue flashing	Connection to the server is being established	Wait until the connection is established and the LED lights permanently blue.
	Permanent blue lighting	Connection to the server is being established	Normal mode - you can continue operation.
	Fast yellow flashing	No connection to network or router	Connect the Access Point to the network/router.
	Permanent yellow flashing	No Internet connection	Please check the Internet connection and firewall settings.



5.1.4 Register Access Point to the server

If the connection to the server is established, you can register your Access Point to the server.

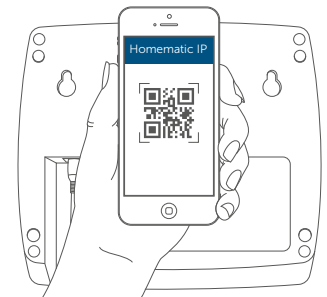
- In the app, tap the "Scan" button.
- Scan the QR code on the back side of your Access Point. Therefore, position the QR code in the centre of the frame of your QR scanner integrated in the app.



After scanning the QR code, "QR code detected" is displayed in the app for confirmation.

 Alternatively, you can manually enter the individual device number (SGTIN) of your Access Point. This can be found under the QR code on your device. Therefore tap on the button "Enter", enter the last four numbers of your SGTIN manually and confirm after entering all numbers with .

- Tap on "Yes" if the device LED of your Access Point lights up permanently blue.

 If this is not the case, tap on "No" and follow the instructions in the app.

- The Access Point is registered to the server. For confirmation, press the system button of your Access Point.
- After successful registration, the Access Point is set-up immediately ready for use. Tap on "Done" and you will get to the homescreen of the app.

5.2 Homematic IP app

5.2.1 Setup screen

After registration of the Access Point, the setup screen offers three options:

- Teach-in device
- Define location for weather data
- Define PIN

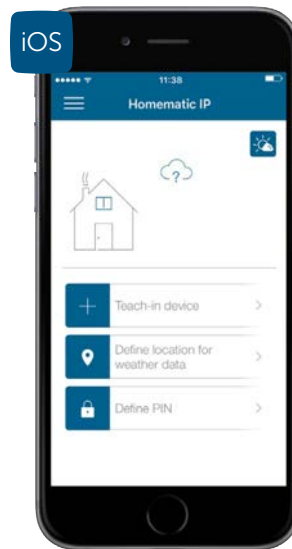

Figure 2: Screenshot setup screen

Define location for weather data

- Tap "Define location for weather data". In the search field, enter the name of the city or postcode.
- Select the location for your weather data and tap "Done".

Define PIN

- In the field "Define PIN", enter a freely selectable 4-digit combination of numbers and tap "Done".

5.2.2 Home screen

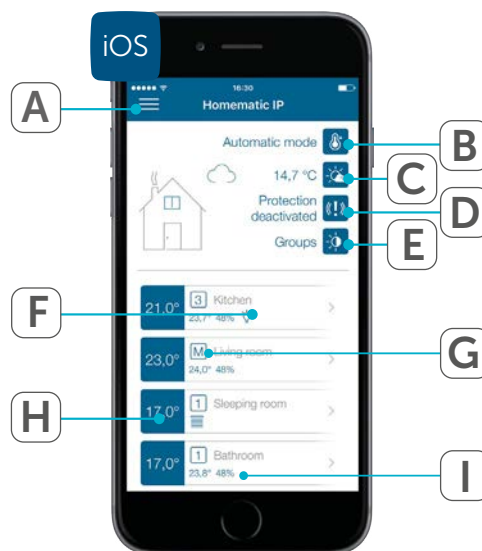

Figure 3: Homematic IP homescreen

- (A) Main menu
- (B) Automatic or eco mode
- (C) Location and weather information
- (D) Alarm mode (deactivated, presence mode, absence mode)
- (E) Switching groups
- (F) Room
- (G) Current heating profile
- (H) Current setpoint temperature
- (I) Icons (e.g. radio communication, open window, low battery)

5.2.2.1 Location and weather information

Immediately after registration of the Access Point you have defined in the setup screen the location for weather data at which your Homematic IP system is installed. Afterwards, location-based information is available on the homescreen of the Homematic IP app after tap on the weather icon.

These include:

- current outside temperature,
- current sunrise time,
- current sunset time,
- current humidity,
- current wind velocity including the prevailing wind direction.

If you have installed a Homematic IP Light Sensor – outdoor, also the current light intensity is displayed in lux.



Figure 4: Screenshot weather data

The displayed weather data is collected by the app via the online service OpenWeatherMap and provides the data also for other functionalities like the automatic control of shutters, blinds and awnings. Alternatively, you can display the weather data measured by your Homematic IP weather sensors.

Via the "Sort" button at the top right of the screen you can arrange the weather view order. The temperature on the homescreen is collected by the data source that is sorted to position 1.

In the device settings of the weather sensor you can adjust further settings.

- In the menu, tap "Device overview" and select the weather sensor.
- In the next step, you can select the brightness threshold value for sunshine detection to adjust the brightness sensor to your surrounding (default value:) 3500). You can select the value between 0 and 100,000. The higher the brightness value, the stronger the brightness area in the outside area needs to be in order to be detected as 'sunshine'.
- Via the measurement data filter you can select, how the values of the wind sensor are detected. The following options are available:

Current: Sensor value at the transmission time of the wind velocity

Minimum: Smallest wind value between two transmissions (approx. 3 minutes)

Maximum (default): Greatest wind value between two transmissions (approx. 3 minutes)

With this option, also wind gusts of wind are detected correctly.

Average: Average value of the last 3 minutes

5.3 Teaching-in devices

To integrate your Homematic IP devices into your smart home solution they must be registered to the Access Point and thus to the server as well. After this registration, a process called "Teaching-in", the devices are displayed in the app and can be set up and configured.

The order for teaching-in several devices is optional for you. It is, however, recommended to go from room to room to teach-in and install the devices one after the other and to configure the devices after all devices have been integrated.

The teach-in procedure is the same for all Homematic IP devices:

- Tap on the main menu icon (☰) (Android) or (☰) (iOS) and there on "Teach-in device".

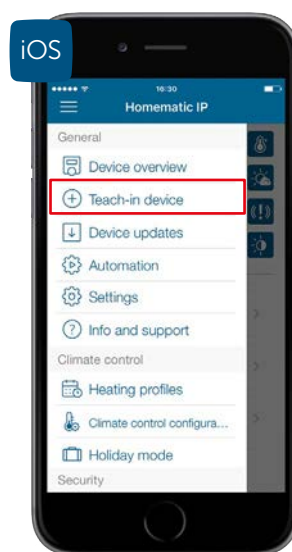

Figure 5: Screenshot menu teach-in device

- Via the app you will be asked to activate the device you want to teach-in, i.e. to establish the power supply.
- Insert the batteries for battery operated devices or remove the insulation strip. Plug-in mains operated devices into a socket.

As soon as the respective device is supplied with power it will appear in the app.

- Follow the instructions in the app. All devices of your Homematic IP system are registered to the server either via scanning the QR or entering the last four digits of the device number (SGTIN).



QR code and SGTIN can be found on the supplied device stickers or on the backside of the Access Point. You will find the SGTIN also in the battery compartment of battery supplied devices. Please keep the sticker in safe place.



If one or more numbers have not been entered correctly, the last numeric keypad of the SGTIN appears in red. In this case, delete the numbers and correct your entry.

- Confirm your entry with ✓.

- In the next step, allocate the taught-in device to one or more **solutions** (e.g. security, climate control and/or light and shadow).



Devices that can be used in one solution only, e.g. the Homematic IP Radiator Thermostat, are automatically allocated to a solution (e.g. climate control). In this case, the request for allocation is skipped. For devices that can be used in connection with more than one solution, as for example the Homematic IP Window / Door Contact, you can select in the next step, in which solutions (e.g. climate control and/or security) you want to use the device.

- Allocate the device to a **room**. Select a room that is already available or create a new room by tapping on "New room" (Android) or "Create new room" (iOS).
- Assign a **name** for the device. You can optionally change the device name generated by the system or add a new name.



Select the descriptions of the devices and rooms so that clear allocation is possible later on. Via the app you can rename the devices and rooms at any time.

In the next step, the app will inform you about successful teaching-in of the device. Depending on the device type or system configuration, additional options will be displayed.

- If you want to connect another device tap "Teach-in another device". The teach-in procedure starts again.
- If you have already defined one or more groups you can tap on "Add device to a group" to integrate the device into a group. Simply follow the instructions in the app.
- If you have connected a device that allows allocation of a time profile (like switching or shutter actuators, for example) you can add the device to a time profile.
- Simply tap "Done" if you do not want to use any additional option.

When teaching-in the following devices, the app offers a list with all existing rooms. You can either select one of these rooms or enter the description for a new room with a tap on "New room". The newly taught-in device automatically appears in the device overview of the previously selected room.

In the following chapters you will find detailed information about the configuration of the system using the Homematic IP app.

6 GENERAL SYSTEM CONFIGURATION

6.1 Main menu

In the main menu you can adjust the settings for your Homematic IP system.

- Tap on the main menu icon (☰) (Android) or (☰) (iOS).

In the main menu you can select between the following options (depends on your system configuration):

- General
 - Device overview
 - Teach-in device
 - Device updates
 - Automation
 - Camera
 - Settings
 - Info and support
- Climate control
 - Heating / cooling profiles
 - Climate control configuration
 - Holiday mode
 - Hot water configuration
- Security
 - Alarm protocol
 - Alarm configuration
 - Light configuration
 - Presence mode
- Light and shade
 - Groups
 - Time profiles
 - Shutter configuration

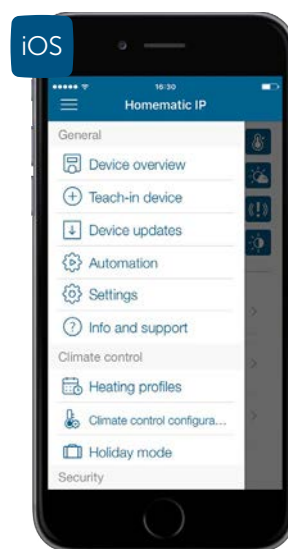

Figure 6: Screenshot main menu (1)

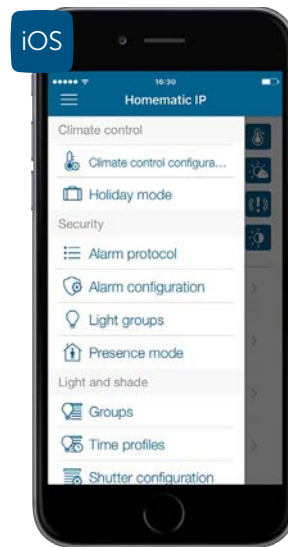

Figure 7: Screenshot main menu (2)



Please note that only menu items of available devices in your system are displayed. If, for example, you are not using devices of the security solution, the menu item "Security" is not displayed.

6.1.1 Device overview

In the device overview of your app you can manage your devices.

- Tap on the main menu icon (☰) (Android) or (☰) (iOS) and on "Device overview".

In this menu, all taught-in devices are clearly displayed room by room. (Devices that are taught-in but have not been allocated to a room are displayed at the top of the device overview in the field "Not allocated".)

All rooms with the corresponding devices follow in alphabetical order or in the order that you have defined in the menu item "Display of rooms".

In the default setting, all devices are listed. After tap on "All" (Android) or "Filter" (iOS) you can filter the devices by single rooms.

By tapping on the device name you can configure the single devices. The configuration options are different for each device. You have the opportunity to change the allocation or e.g. to activate/deactivate the operating lock.



Devices for which the operating lock is activated can be operated only via the app, not via the device itself.

In addition, you can e.g. set the temperature offset for radiator thermostats to compensate deviations in temperature. For window contacts, an individual message delay between 0 and 60 seconds can be defined.



A message delay can be useful if a window is opened only shortly and the heating shall not be turned down.

In addition, the device overview as well as the homescreen of the app offer further information, e.g. about the allocation of devices to a solution or if in rooms with installed window / door contact a window or door is opened. In rooms including a wall thermostat you can see at a glance the current room temperature and humidity.

In addition, with a tap on the device description you will find an information icon at the top right of the screen with additional information for each device in the following order:

- SGTIN: SGTIN indicates the individual device number of the device.
- Device type: Shows the short description of the device.
- Current firmware: Indicates the currently installed firmware version of the device.
- Update status: Here you are informed if your firmware is up to date or if a new firmware version is available for the device and a device update has to be performed.
- Connection quality: Shows the connection quality between Access Point and device with a bar graph.

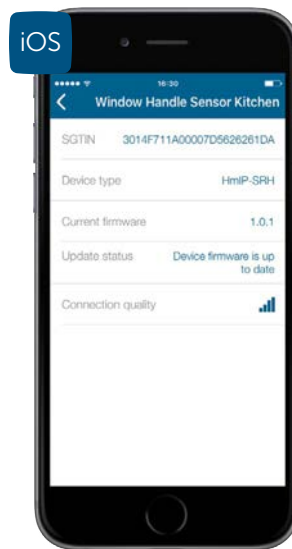

Figure 8: Overview device information

6.1.1.1 Range extension

In case of extremely unfavourable structural conditions it may occur that the quality of the radio communication between your Homematic IP Access Point and the Homematic IP devices is not satisfying. By using the Homematic IP Pluggable Switch or a Homematic IP Pluggable Switch and Meter it is possible to transfer the radio signal of the relevant device via app.

When applying range extension, the transmitter (here, the window sensor) first tries to transmit a signal to the receiver (here, the radiator thermostat).

Normal radio communication:

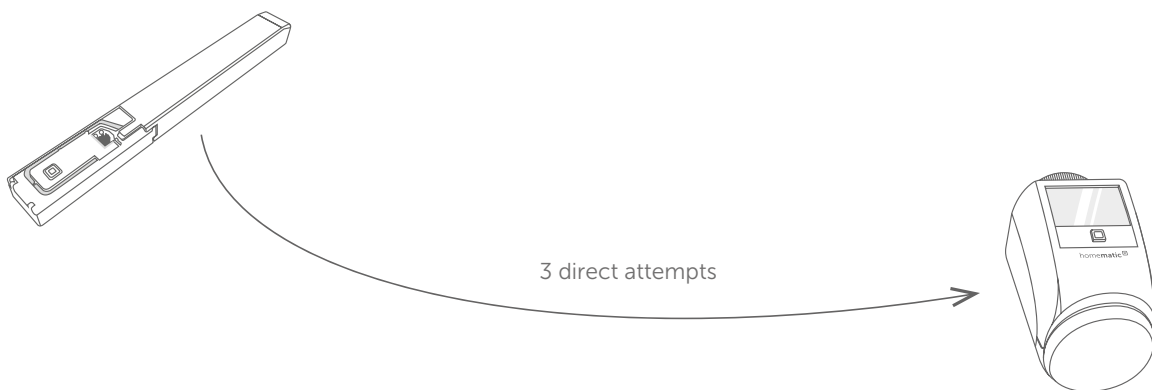

If the command is not received after the third try, the transmission command is transferred from the transmitter to the router (here, the pluggable switch/pluggable switch and meter) and is forwarded to the receiver.

Radio communication, if direct transmission is not possible:

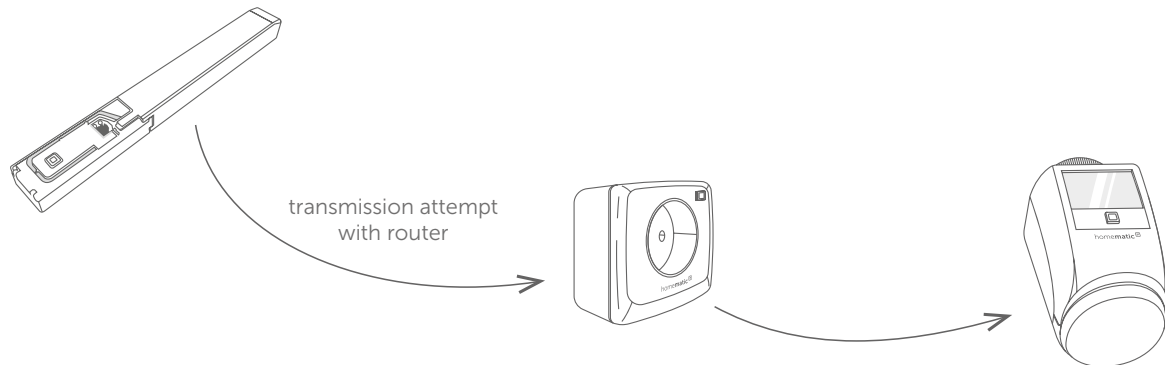

Not more than two pluggable switches/pluggable switches and meter, that are configured for range extension, can be used as router in a row.

After the range extension has been set-up and the functionality has been verified, the position of the Homematic IP components that are included into the range extension as well as the pluggable switches/pluggable switches and meter should not be changed any more. Please keep this in mind especially for mobile devices like Homematic IP Remote Controls.



The Pluggable Switch/Pluggable Switch and Meter can continue to be used for normal operation and switching of connected loads, even if range extension is activated.



Activation of the range extension via the Homematic IP Pluggable Dimmer is not possible.

To activate the range extension, proceed as follows:

- Tap on the main menu icon and there on "Device overview".
- In the device overview, select an installed Homematic IP Pluggable Switch or Homematic IP Pluggable Switch and Meter.
- Tap on "Range extension".

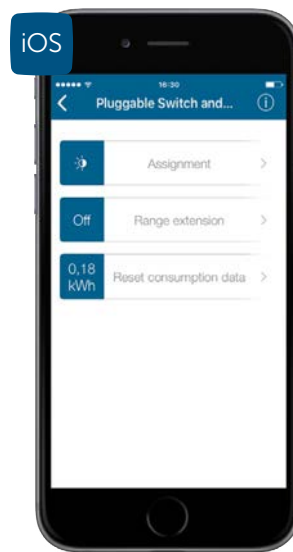

Figure 9: Screenshot device settings pluggable switch/pluggable switch and meter

- In the following screen tap on "Activate". By tapping "Done", the range extension will be activated.



Only activate the range extension if it is really required in order to avoid any unnecessary routing or radio traffic. You can deactivate the range extension via the app at any time.

6.1.1.2 Overview of symbols

In the device overview, as well as in parts of the homescreen, certain information is indicated via symbols.

Symbol	Meaning
	Eco mode
	Cooling mode
	Party mode
	Holiday mode
	Low battery
	Window open
	Window tilted
	Light on
	Motion detected
	Water alarm

Symbol	Meaning
	Sabotage message
	Radio interference
	Sunrise
	Sunset
	Shutter/blind moved down (from 1 % shutter level)
	No time profile has been allocated to the device.
	Shutter/blind moves
	Slat position
	Smoke alarm

6.1.1.3 Rename and delete devices

All devices displayed in the device overview can be renamed or deleted here.

Rename devices

Android

- Tap and hold down the device you want to rename.
- Tap on the pen icon () in the menu bar.
- Enter a new name. After tap on "Confirm" the new name will be saved.

iOS

- Select the device you want to rename, swipe from right to left and tap on "Rename".
- Enter a new name into the text box. After tap on "Confirm" the new name will be saved.

Delete devices

Android

- Tap and hold down the device you want to delete.
- Tap on the trash icon () in the menu bar.
- Confirm by tapping on "Delete" that you really want to delete the device.

iOS

- Select the device you want to delete, swipe from right to left and tap on "Delete".
- Confirm by tapping on "Delete" that you really want to delete the device.



If you delete a device the factory settings of the device have to be restored before it can be taught-in again and continued to be used. For further information, please refer to the user manual of the corresponding device.

6.1.2 Device updates

To keep your Homematic IP devices up to date, Homematic IP offers the opportunity to update the device software (firmware) of the components. The device firmware controls all functionalities of your Homematic IP devices.

Usually, background updates are used for Homematic IP. In this case, the device firmware is updated in the background via radio connection. Some other devices are updated via 'live update', which must be executed directly in the Homematic IP app. Both variants will be explained below.

6.1.2.1 Background Update

The background update is an especially comfortable method to provide new firmware to single devices, e.g. radiator thermostats, via radio communication. If you want to update the device software of your Homematic IP components, you can select between two options available via the main menu under "Settings", "General settings", "Device update mode":

Manual installation of updates

If a device software update is available for one or more devices, the relevant devices are listed in the main menu in the menu item "Device updates". You can start the update procedure. This mode is selected in the default settings as it offers a better overview. For some Homematic IP devices (e.g. window contacts) there is no automatic installation of updates available due to security reasons.

- Select in the menu item "Device updates" the device for which you want to update the device software by tapping on the respective field. It is verified, whether the device update can be performed.
- Tap on the button "Perform device update".



Figure 10: Screenshot device update

If a device update is available for several devices, please perform the one after another as several updates cannot be performed at the same time due to technical reasons.



Please note that the functionality of the devices is limited during the update. For some Homematic IP devices it is necessary to press the system button on the device so that the update can be directly installed. In this case you are expressly informed via the app.

Automatic installation of updates

If you select the option "Installing updates automatically" the update of the device software is performed in the background.

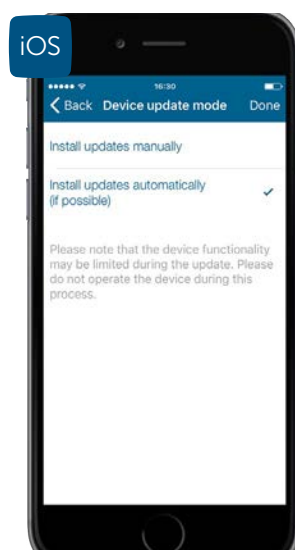

Figure 11: Screenshot automatic installation of updates

In the Homematic IP cloud a device list with the relevant serial numbers and firmware versions is provided. If for one or more of your Homematic IP devices a new device software is available, the Homematic IP cloud forwards this information to your Homematic IP Access Point. This transfers with every send radio telegram a part of the new firmware file into the memory of the device for which an update is available.

As soon as the firmware file has been transferred completely it will be installed automatically. Thus, confirmation via the Homematic IP app is not necessary.



Please note that the option "Install updates automatically" is not available for all Homematic IP devices. For security reasons updates of devices like the Homematic IP Window and Door Contact must be installed manually. Follow the instructions in the app and press the system buttons of the device afterwards.

Via 'Update status' in the device settings, the following information can be displayed:

- Device firmware is up to date The latest firmware version is installed and does not need to be updated.
- Device update is prepared: The new device firmware version is transferred step by step to the device in the background. In some cases, this procedure may take several hours or days.
- Device update can be performed: Via 'Device updates' in the main menu it will be displayed, for which device the device update can be performed. Follow the instructions in the app. This message only appears, if the device update mode is set to 'Manually'. Otherwise, the device update is transferred automatically.



Please note, that the time for proceeding the update cannot be influenced (e.g. by operation or pressing the device button).

6.1.2.2 Live Update

For some devices, like the radiator thermostat and the window sensor from the Homematic IP Starter Set Heating – easy connect, a live update via the Homematic IP app can be used instead of the background update. During the live update, the firmware update is performed by the user manually via the app.



During the update, there is no connection between the Access Point and the connection devices. As soon as the update has been performed completely, the communication will be established again.



For some Homematic IP devices it is necessary to press the system button on the device so that the update can be directly installed. In this case you are informed via the app.

As soon as a new device firmware is available, the message “Device update available” appears in the main menu under “Device updates” or in the homescreen (depending on the configuration).

To perform the live update, please proceed as follows:

- Tap on “Device updates available”. A list with all devices available for an update will be displayed.
- Tap on the desired device and confirm the start of the device with “Yes”.
- The device update will be performed within a few minutes. Meanwhile, the progress of the update is given as a percentage.



Do not cancel the update while it is in progress and do not disconnect the Access Point from power supply.

- Tap on “OK” (Android) or “Done” (iOS) afterwards.
- If necessary, repeat this procedure for further devices.

If the live update cannot be performed correctly, please try again and follow the instructions in the app.

6.1.3 Automation

The "Automation" function is used to create individual rules and to combine almost all devices and conditions of different application areas with each other. You will find further information in the section (see sec. „11 Groups, Time Profiles and Automation" on page 166).

6.1.4 Settings

In the menu item "Settings" you can adjust general settings for the operation of your system. You can for example

- change the location for weather data and time zone,
- change or add a PIN for the app,
- see the user overview of your system,
- select the device update mode,
- select which notifications and which notification sounds you want to receive on your smartphone,
- select which rooms are displayed by default on the homescreen and define the order,
- adjust the settings of the consumption metering as well as
- recall an activation key for connecting voice command services with Homematic IP
- set-up the multi Access Point management for your smartphone.

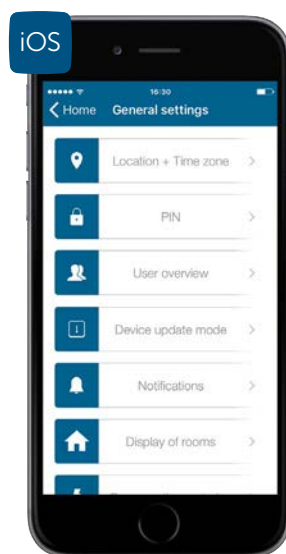

Figure 12: Screenshot General settings

6.1.5 Multi-Access Point management

You can add additional Access Points to your Homematic IP system to configure and control several Homematic IP installation via an app. In this way, you can for example control your system in the house and in your holiday home in one app.



It is recommended to use not more than five Access Points with one app.

- Tap on the main menu icon (☰) (Android) or (☰) (iOS) and there on "Settings".
- Select "General settings" in the menu item "Multi-Access Point management".
- In the following screen tap on the + icon
- Select a new name for the system you want to install additionally ("holiday home", for example).
- Connect your new Access Point. Follow the instructions in the app.

After connecting the new Access Point you can see directly in the homescreen the current installation. Tap on the name of the installation (e.g. "My home") in order to change to other installations.

Alternatively, you can select via the menu item "Multi-Access Point management" which Homematic IP system you want to control using your Homematic IP smartphone app. Tap on the name that you have assigned to your installation and afterwards on "Done".

The Access Points and installations integrated via the app can be renamed and deleted via the menu at any time, if required.

6.1.6 Info and support

In this menu item you can request further information about Homematic IP and find the contact details of the support hotline.

- Tap on the main menu icon (☰) (Android) or (☰) (iOS).
- Tap "Info and support".

You can select between the following menu items:

- User guide
- News
- Support
- EULA
- Privacy Notice
- Open source licenses
- Legal notice
- Replacing the Access Points (open by tapping 5 times on the Access Point version at the bottom of the screen).

Furthermore, you will find information about the currently installed app versions as well as the version of the Access Point in the menu item under "Info and support".

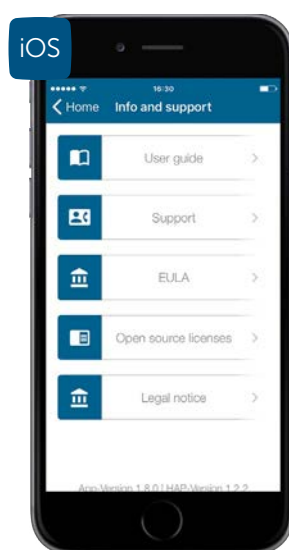

Figure 13: Screenshot Info and support

6.1.6.1 User guide

Here you can download the current version of the Homematic IP User Guide directly on your smartphone to receive current information about Homematic IP also while being away from home.

6.1.6.2 News

Here, you will find information on new functions of the current Homematic IP smartphone app version.

6.1.6.3 Support

For further support you will find the current phone number of the Homematic IP support hotline in this menu item. When opening the support menu, the app generates a six-digit support token. The code is used by the support staff to recall completely anonymous information about the condition of your Homematic IP system and to offer specific support.

6.1.6.4 EULA

Via the menu item EULA (End User License Agreement) you can find information about the license conditions, rights and duties that you have agreed to by accepting the General Terms and Conditions during installation of the app.

6.1.6.5 Open source licenses

This menu item informs about the open source software that has been used in the Homematic IP app as well as the corresponding license conditions and usage rights.

6.1.6.6 Legal notice

Here you are informed that the weather data of the Homematic IP smartphone app is provided by an application programming interface (API) of the online service OpenWeatherMap. In addition, for Android devices an information about using Google Maps is displayed.

6.1.6.7 Replacing the Access Point

In case it is necessary to replace your Homematic IP Access Point this can be easily realised. Therefore, the new Access Point imports all data of your installation. Your previously used Access Point will be put out of operation.



Please note that the factory settings of your new Access Point have to be restored if required. You will find an instruction on how to restore the factory settings in the user manual of your Access Point.

- Disconnect your old Access Point from the power supply.
- Tap in the app homescreen on the main menu icon (☰) (Android) or (☰) (iOS) and select "Info and support" in the main menu.
- Here, tap five times quickly on the displayed version line in gray at the lower edge of the screen.
- Tap "Continue" and follow the instructions in the app step by step.

After the exchange procedure is finished, your new Access Point is set up and immediately ready for use.

7 CLIMATE CONTROL

The Homematic IP products for heating and climate control offer intuitive and comfortable control of your indoor climate – room-by-room and according to your personal needs. No matter if you have installed conventional radiators or a wall panel/floor heating – Homematic IP ensures optimum living comfort. Depending on the configuration and smart combination of devices for heating control, up to 30 % on energy can be saved. The room temperature can be regulated via radiator thermostats, an installed wall thermostat or simply via app. Homematic IP can also be used to create individual heating profiles. Thus, a pre-warmed bathroom awaits you in the morning. And even if you come home from work in the evening, your home is set to your personal comfort temperature.

7.1 The benefits

Energy costs have more than doubled over the last years. A change in this trend is not yet in sight. Considering the continuously increasing energy prices, one of the essential advantages of a smart, demand-based climate control solution like Homematic IP is obvious: A reduction of the heating costs by up to 30 percent has not only a positive effect on cost savings. And you still do your bit for the environment. By reducing the CO₂ emission significantly, you can save heating energy and improve your environmental footprint.

Another advantage is the additional comfort. After setting up and configuring your Homematic IP climate control solution, your heating is controlled mostly automatically and makes everyday life easier. You can still react flexibly to changing circumstances and adjust your desired temperature immediately according to your needs.

7.2 Installation planning

For most households, the Homematic IP climate control solution, offering easy installation and intuitive operation, is an attractive method for saving energy costs and at the same time to benefit from the increased comfort that is offered by this solution. Because in private households almost three quarters of the energy costs is used for heating rooms, i.e. the energy costs. The saving potential is considerable and compared to other energy-saving measures it requires less effort. The following provides a number of tips and information about planning your installation.

For which heating systems can the Homematic IP climate control solution be used?

- **Heating system with conventional radiators**
The Homematic IP climate control solution is optimised for the application in connection with the most widespread heating systems. Manually operated conventional radiator thermostats are replaced by electronic radiator thermostats. The room temperature is regulated via the Homematic IP smartphone app according to individual needs and times.
- **Conventional radiators and electric heaters**
In addition, many households use one or more electric heaters for heating remote

rooms such as garden houses, single or rarely used rooms, separately from the central heating. Also for this system the climate control solution is ideal: In connection with the Homematic IP Pluggable Switch or Pluggable Switch and Meter and a Wall Thermostat, the temperature in rooms with electric heaters can be adjusted precisely and based on your demands. Another advantage: Thanks to the measuring function in the device you can always use the Homematic IP smartphone app to monitor the energy consumption and the energy costs.

- **Floor heating systems**

With the growing spread of alternative energy sources such as heating pumps and solar collectors, floor heating systems become increasingly popular. In this combination it plays its full benefit, such as the possibility of operating in the low-temperature range. Floor heating systems are often considered to be very comfortable and also offer more freedom when it comes to furnishing and designing rooms.

The Homematic IP Floor Heating Actuator offers the opportunity to control your floor heating room-by-room comfortably and demand-based, thus adapting the room temperature to your individual needs.

As basic solution, a floor heating actuator can be connected directly via radio without any cable with one or more battery-operated wall thermostats (HmIP-WTH-2) or wall thermostats with switching out (HmIP-BWTH or HmIP-BWTH24) for time-controlled regulation of the room temperature. In connection with the Homematic IP Access Point you can control your floor heating at any time and almost anywhere via a smartphone app. When using a mixed heating system, the app takes control of both the floor heating and conventional radiators.

The system is suitable for initial installations as well as retrofitting an existing floor heating system. The Homematic IP Multi IO Box also provides a separate control unit for switching boilers, circulation pumps and heating pumps.

Which Homematic IP devices do I need to install an effective climate control solution in my flat/my house?

The following will indicate an overview of devices that can be used for the climate control solution. Apart from the Access Point, the number and type of devices is variable.

- **Homematic IP Access Point**

Since the Access Point transfers the configuration data and operating commands to the single Homematic IP components it should be placed in a central position to ensure ideal radio connection to the devices.



Note: For further information about the ideal position of your Homematic IP components please refer to chapter "3.3 Wireless range".

- **Radiator thermostats**

For sensible and effective heating control it is advisable to equip all radiators with a radiator thermostat.

- **Window and door contacts / window handle sensors**

As the window and door contact – optical, the window / door contact – invisible installation as well as the window handle sensor ensure automatic reduction of the room temperature in connection with one or more radiator thermostats you should mount the sensor to all windows that are opened regularly for ventilation.

- **Wall thermostats**

You should mount wall thermostats in rooms with several radiators. A wall thermostat is also an advantage in rooms where measuring the humidity is useful, such as bathrooms or bedrooms. Particularly if radiators are installed in an unfavourable position, for example in recesses. A wall thermostat offers advantages because the

room temperature is measured where the sensor is located, which has a positive effect on temperature control in the room.

For floor heating systems and compatible surface heating systems, each room is equipped with a wall thermostat for temperature control.

- **Wall thermostat with switching output**

The wall thermostat with switching output enables easy upgrading of conventional floor heating control systems to a smart regulation of the room temperature by replacing the existing bimetal controller. The 230 V or 24 V actuators for floor heatings are switched via the relay output (HmIP-BWTH) or triac output (HmIP-BWTH24) according to the defined heating profiles.

- **Temperature and humidity sensors**

Alternatively, you can use a Homematic IP Temperature and Humidity Sensor (HmIP-STH) or Temperature and Humidity Sensor with display (HmIP-STHD) instead of the wall thermostat. Please note that only one wall thermostat or temperature sensor per room can be used.



Please note that Homematic IP Wall Thermostats of the first generation (HmIP-WTH) can only be used to control floor heating systems after a software update (see sec. „6.1.2 Device updates“ on page 40).



Note: Install wall thermostats at a height of approximately 1.5 m and if possible not on cold external walls or other areas which can lead to measurement errors, for example in places with direct sunlight or in the vicinity of other heat sources.

- **Wall-mount remote control**

If possible, the wall-mount remote control should be mounted in the area of the entrance door of the house or flat to activate the eco mode for all rooms with radiators when leaving the house. Using several wall-mount remote controls per installation is also possible, e.g. to equip the front door and the back entrance of a house. At the same time you can comfortably reduce the temperature of several radiators at the push of a button.

- **Pluggable Switch/Pluggable Switch and Meter**

For sensible and effective control of electric radiators as well as for measuring the energy consumption, it is advisable to equip all electric radiators with a pluggable switch or a pluggable switch and meter. In connection with a Homematic IP Wall Thermostat the devices can be used for exact regulation of the room temperature.

- **Floor heating actuators**

The floor heating actuators can be used to control floor heating systems with up to 6 or 10 heating zones as well as one heating or circulation pump.

Every second heating zone is equipped with two clamp terminals. This allows you to operate up to 9 or 15 heating circuits per installation. When using the devices HmIP-FAL24-C6 and HmIP-FAL24-C10 make sure that a suitable transformer, e.g. the Homematic IP Transformer for Floor Heating Actuators – 24 V, is used.

- **Multi IO Box**

Connect a Multi IO Box to your boiler, the circulation pump or a heating pump for demand-based control of your heating system or the hot water tank. The Multi IO Box offers a wide range of configuration options that allow you to adapt the operation of your boiler, circulation or heating pump to your personal needs. We recommend that you have the installation and configuration carried out by a local distributor.

Which devices are needed apart from the Homematic IP components?

Since Homematic IP is an Internet-based system, you need an Internet connection with a standard router. The Homematic IP Access Point, the "heart" of the system, is connected to the router via a network cable over a free network connection.

The configuration and operation of your Homematic IP climate control solution is done via an iPhone or Android smartphone app. The Homematic IP app is compatible with iPhones from iOS version 8.0 as well as for Android smartphones from version 5. The app is available for free download both for Android and iOS.

7.3 Configuring the climate control solution for each room

After you have installed and set-up your solution as described in section “5.3 Teaching-in devices”, you can configure the climate control solution and adapt it to your individual needs.

7.3.1 Operating modes

Your Homematic IP climate control solution offers five operating modes:

- In **automatic mode**, the system controls the room temperature according to your defined and selected heating profiles.
- In **manual operation**, you can manually regulate the room temperature independent from the heating profiles.
- In **eco mode**, which can be activated via the homescreen of the app or via the Homematic IP Wall-mount Remote Control, all or individual rooms equipped with radiators or electric heating systems are automatically adjusted to a predefined eco temperature (reduced temperature), for example after pressing the wall-mount remote control when leaving the house.
- In **party mode**, you can keep the room temperature to a certain temperature value for an exact period to be defined.
- In **holiday mode**, you have the option to reduce the room temperature until a defined point in time to a freely selectable temperature value in case of longer absence. In holiday mode, also the temperature of the floor heating system is reduced.

7.3.1.1 Manual operation

If you select the profile "Manual" for a room, you have the option to select a room temperature that is kept constant within the defined minimum and maximum temperature. The stored heating profile of the corresponding room is not active in the meantime.

- In the homescreen, tap on the room for which you want to activate the profile "Manually".
- Tap on the currently activated profile.
- In the "Delete visible profiles" pop-up window, tap "Manual" and select the desired room temperature using the control dial.
- Tap "Back" (⬅️) or "Home" (iOS) to return to the homescreen of the app.

7.3.1.2 Party Mode

For a party or similar events another temperature can be desired for a certain period of time. You can use the party mode to adjust the room temperature for a precisely defined period of time.

- In the homescreen tap on the room for which you want to activate the profile "Party mode".



Figure 14: Screenshot selecting the party mode

- Tap on the currently activated profile.
- In the drop-down menu "Visible profiles", tap on "Party mode".
- Select the time for activating the party mode and tap "Continue".
- Use the control dial to select the desired room temperature.
- Tap "Back" (⬅️) or "Home" (iOS) to return to the homescreen of the app.



After the time defined for the party mode has expired, the room temperature is controlled according to the profile that has been selected last.

7.3.1.3 Holiday mode

By activating the holiday mode you have the option to reduce the room temperature until a defined point in time to a freely selectable temperature value in case of longer absence and thus to save energy.

In contrast to the eco mode, the temperature in the holiday mode is reduced in all rooms, i.e. also in rooms which are heated exclusively with a floor or wall surface heating system.

Activating the holiday mode

- Tap in the app homescreen on the main menu icon (☰) (Android) or (☰) (iOS) and select "Holiday mode" in the main menu.
- Tap again on "Holiday mode" (iOS) and select the date and time.



Figure 15: Screenshot holiday mode configuration

- Tap "Continue", use the control dial to adjust the room temperature for the holiday mode and confirm with "OK".

The set temperature is maintained until the selected time. Afterwards, the system changes back to automatic mode with the stored heating profile for the single rooms.

Deactivating the holiday mode

- Tap in the app homescreen on the main menu icon (☰) (Android) or (☰) (iOS) and select in the main menu "Holiday mode".
- Android: In the following pop-up window you can deactivate the holiday mode by tapping on "Confirm".
- iOS: Tap again on "Holiday mode" (iOS) and confirm the deactivation in the following dialogue with "Yes" (iOS).



If the eco mode is activated you are asked via the app to confirm the change between the eco mode to the holiday mode. The same applies to the change from holiday mode into eco mode.

7.3.2 Room menu

- Select a room via the app homescreen. Tap on the menu icon (☰) (Android) or "Edit" (iOS). You can select between five menu items.

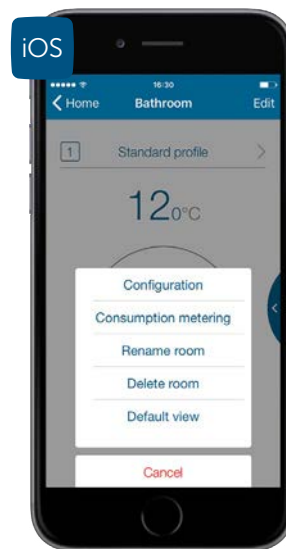

Figure 16: Screenshot room menu

7.3.2.1 Configuration

Via this menu item you can configure the rooms of your choice.

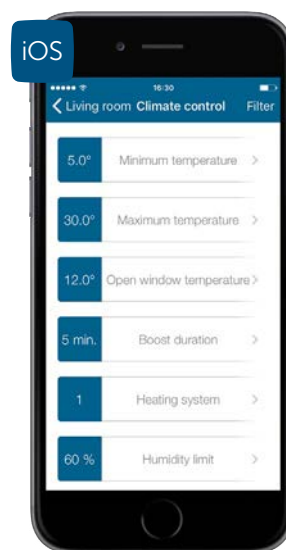

Figure 17: Screenshot configuration menu

Minimum temperature

- Tap "Minimum temperature" and select the desired temperature via the control dial. After tap on "Confirm" (Android) or "Done" (iOS) the selected minimum temperature is stored in the system.

Maximum temperature

- Tap "Maximum temperature" and select the desired temperature via the control dial. After tap on "Confirm" (Android) or "Done" (iOS) the selected maximum temperature is stored in the system.



The minimum and maximum temperature defined via the menu item "Configuration" has priority over the selected heating profile of the corresponding room.

If, for example, you have selected 20 °C for the maximum temperature of a room, this temperature limitation applies even if you have set a temperature of 22 °C in one or more heating phases of the selected heating profile. This also applies to the minimum temperature.

Open-window-temperature

Use this menu item to determine the temperature of the relevant room to which the radiator thermostat(s) will be lowered when you open the window.

- Tap "Open window temperature" and select the desired temperature via the control dial. After tap on "Confirm" (Android) or "Done" (iOS) the selected open window temperature is stored.

Boost duration

Use this menu item to define the duration of the *boost function*. If you activate the boost function via the app or the thermostat, the thermostat's valve is fully opened for the set time period, so that an optimum comfort temperature can be achieved quickly.

- Tap "Boost duration" and select the desired boost duration via the control dial. After tap on "Confirm" (Android) or "Done" (iOS) the selected boost duration is stored in the system.

Heating system

This menu item allows you to select the heating system that you want to control with your floor heating actuator. You can select between the following five options:

- **1. Standard**
Select this mode for standard floor heating systems in conventional buildings.
- **2. Low energy**
Select this mode if you use a floor or wall surface heating system with a very low flow temperature, for example in an energetically renovated building or new building with low energy requirements.

The remaining three options are reserved for special areas of application and are not relevant for floor and wall surface heating systems.

- **3. Radiator**
With this mode it is possible to regulate water-based radiators via a channel of the floor heating actuator. Therefore, a wired thermal actuator on the radiator is required.
- **4. Passive convector**
Select this mode only when using underfloor convectors, such as those used in front of large window areas.
- **5. Active convector**
This mode is selected only if fan coils are applied that are usually used in office and industrial buildings.

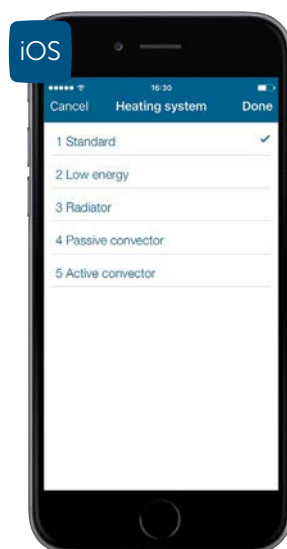

Figure 18: Screenshot configuration menu

Humidity limit

When using a Homematic IP Multi IO Box with connected dehumidifier, the humidity value from which the dehumidifier is activated in order to avoid condensation problems can be set here. For floor heating systems with active cooling operation, the corresponding cooling circuit is also closed.

7.3.2.2 Consumption metering

Devices such as the Homematic IP Pluggable Switch and Meter or the Switch Actuator for brand switches allow both switching on and off as well as the indication of the consumed energy costs of connected devices ("consumers"), for example via the Homematic IP smartphone app. After you have established the power supply and taught-in the corresponding device, you can record the energy consumption of devices that you have connected to the pluggable switch and meter or switch actuator (please observe the technical data in the user manual of the device).

Switching is carried out either via the app or manually via the system button of the pluggable switch and meter or via operation of a push-button.

Setting the consumption parameters

In order for the energy costs of your connected device to be displayed correctly and in the desired currency, it is necessary to enter the price per kilowatt hour for your household first. You will receive the relevant information on your current tariff by your energy provider. Optionally, you can also adjust the currency. To do this, proceed as follows:

- Tap on the main menu icon (☰) and there on "Settings".
- Select the menu item "Consumption metering" in the "General settings" menu.
- Under "Price / kWh" enter your current tariff per kilowatt hour and tap "Confirm".

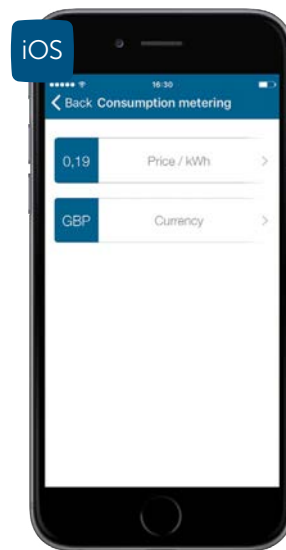

Figure 19: Screenshot settings consumption metering



You can adjust the currency if required under "Settings", "Consumption metering", "Currency". In the default settings, the energy costs are displayed in Euro (EUR).

In the device overview of the app, you can see the power of the device connected to the Homematic IP Pluggable Switch and Meter in watts.

Display of consumption values

- Use the app homescreen to select the room to which the consumer connected to the pluggable switch and meter has been allocated.
- Tap the "Edit"-icon at the top right of the screen.
- Tap "Consumption metering".

Under the menu item "Consumption metering" you will see the consumed energy in kWh as well as the energy costs in the selected currency – individually and in total.

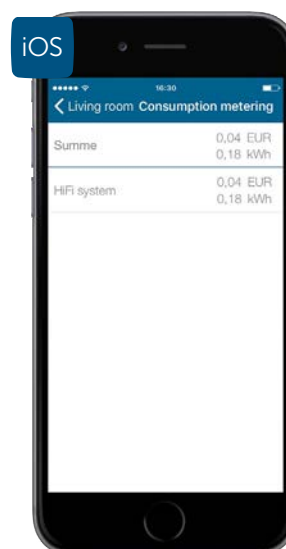

Figure 20: Screenshot display of energy costs and consumption

Resetting the consumption data

The consumption data is continuously metered and summed up. However, you can reset the consumption values back to zero at any time, for example if you want to receive the energy consumption within a certain period of time.

- In the device overview, select the device that is connected to the respective pluggable switch and meter by tapping it.
- Tap "Reset consumption data".

7.3.2.3 Rename room

- Tap on "Rename room".
- Please enter a new name. After tap on "Confirm" the new name will be saved.

7.3.2.4 Delete room

Use this menu item to delete a room.



If there are still devices assigned to a room, you first have to delete all devices in the device overview of the room.

- Tap on "Delete room".
- After tap on "Confirm" (Android) or "Done" (iOS) the room will be deleted.

7.4 System configuration for the climate control solution

7.4.1 Heating and cooling profiles

With heating and cooling profiles you can tailor the heating control for each room to your personal needs and individual routines.

For each room, the Homematic IP app can define up to three different heating or cooling profiles (cooling if you are using floor heating actuators). Within these heating profiles, you can set different switching times for each day of the week and thus regulate the room temperature in a time-controlled manner - with up to six freely definable heating phases per day.

All heating profiles defined can be selected under the corresponding rooms with a fingertip.



Figure 21: Screenshot selecting a heat profile

7.4.1.1 The standard profile

In the app, up to three heating profiles can be created and configured for each room. The standard profile is explained in more detail below:

The default base temperature is 17 °C. The *base temperature* indicates which constant temperature is to be kept in the room when the heating profile is neither in a heating nor in a lowering phase.

In addition, a room temperature of 21 °C is specified from 6:00h to 9:00h and from 17:00h to 21:00h for the weekdays. For Saturdays and Sundays, a room temperature of 21 °C is pre-set from 6:00h to 22:00h.



Figure 22: Screenshot standard profile

7.4.1.2 Adjusting the heating profile

You have six options for adjusting the heating profiles:

- Rename profiles
- Changing the *base temperature*
- Changing the predefined heating phases
- Deleting and adding heating phases
- Copying switching times to other weekdays
- Copying profiles to other profile positions (transferring complete week profiles to other rooms)

Selecting profiles

- Open the main menu (☰) Android or (☰) (iOS) and tap "Heating profile".
- In the "Heating profiles" menu, select the profile of the room you want to adjust by tapping "Standard profile" under the relevant room. The profile is loaded and the profile overview including pre-defined heating profiles for each day of the week is opened.

Rename profile

- Select in the "Heating profiles" menu the profile of the room you want to adjust by pressing and holding.
- Tap on the pen icon in the menu bar, enter a new name and confirm your entry.
- In the profile overview select the profile that you want to rename. Therefore, swipe from right to left. Tap on "Rename" and enter a new name (iOS).

After confirming the entry you will automatically get back into the "Heating profile" menu.

Changing the base temperature

The base temperature indicates, which temperature in a room is held constantly, if the heating profile is neither in heating nor in cooling mode.

- Tap on the top profile bar (Monday).
- Tap on "Base temperature" adjust the *base temperature* via the control dial and tap on "Back" (⬅️) (Android) or "Done" (iOS).



Figure 23: Screenshot changing the base temperature

Changing heating phases

- Tap on the heating phase you want to change. You can now change the corresponding fields beginning (left), setpoint temperature (middle) and end (right) of the selected heating phase. For saving the changes of the profile tap three times on "Back" (⬅️) and afterwards on "Save" (Android) or "Done" (iOS).

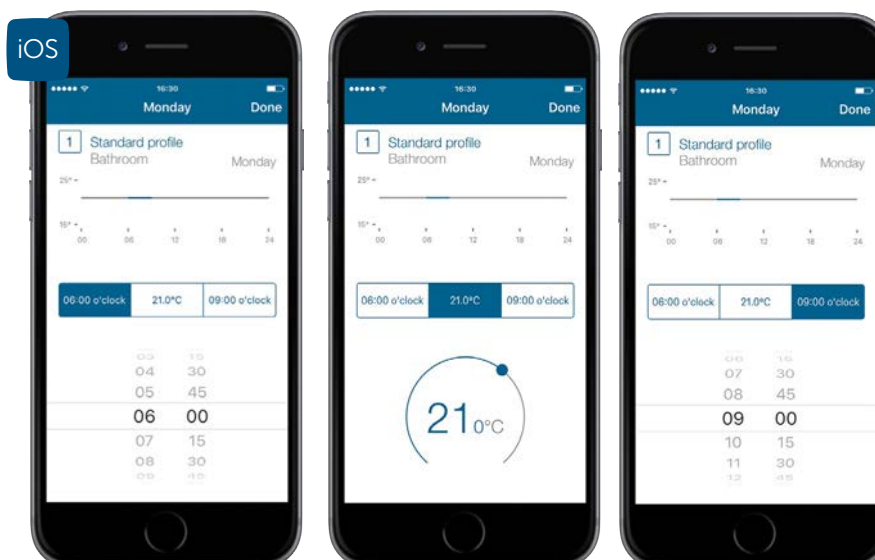

Figure 24: Screenshot changing heating phases

Adding heating phases

- Select in the profile overview of a room a day profile and tap on + (Android) or + (iOS). A new heating phase that you can individually adjust is opened (refer to "Changing

heating phases”).

Deleting heating phases

- To delete a heating phase, tap on ✕ (Android) or swipe from right to left in the field of the selected heating phase and tap on “Delete” (iOS). The heating phase will be deleted.

Copying switching times to other weekdays

This function is used to copy switching time that have been defined for another weekday to one or more additional weekdays. The heating profiles for the selected weekdays can still be adjusted afterwards.

Android:

- Select in the profile overview the day profile you want to copy by pressing and holding. Tap on .
- Select the desired week day and tap on “Confirm”.

iOS:

- Select in the profile overview the day profile you want to copy, swipe from right to left and tap on “Copy”.
- Select the desired week day and tap on “Done”.

Transferring heating profiles to other rooms

This function is used to comfortably copy a pre-defined week profile to other rooms.

Android

- Select in the “Heating profiles” menu the profile that you want to copy to the other profile positions by pressing and holding. Tap on .
- Select the profile positions via the check box and tap on “OK”.

iOS

- In the profile overview select the profile that you want to copy to other profile positions. Therefore, swipe from right to left. Tap on “Copy”.
- Select the desired profile position by tapping and tap on “Done”.

Creating additional heating profiles

In the app you can define up to three heating profiles for each room via the “Heating profiles” menu.

- Tap on the unfold icon of the desired room (.
- In the “Visible profiles” window select at least one additional visible profile and tap “Confirm” (Android) or “Done” (iOS).
- Tap on the selected alternative profile. In the profile overview you can define this profile and if required one additional profile as described above.



Also for this feature it is very useful to copy the switching time to other week days.

7.4.2 Climate control configuration

Via the "Climate control configuration" you will be able to adjust further settings for the regulation of the room temperature. Depending on your components, different configuration possibilities will be displayed.

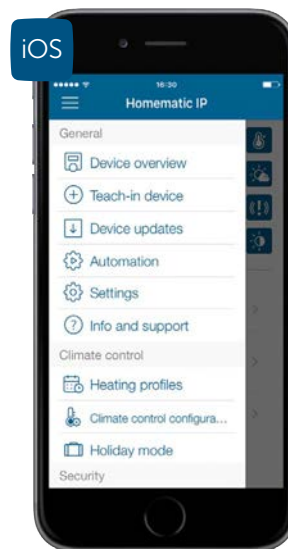

Figure 25: Climate control configuration menu

- Tap in the app homescreen on the main menu icon (☰) (Android) or (☰) (iOS) and select "Climate control configuration" in the main menu.

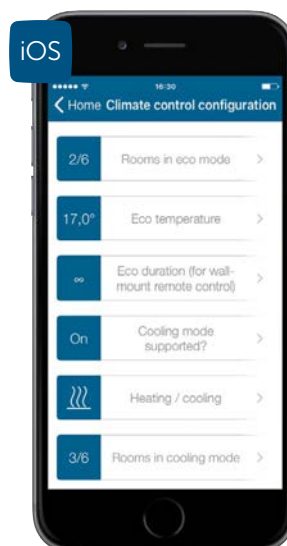

Figure 26: Screenshot overview climate control configuration

7.4.2.1 Eco mode configuration

- Tap "Eco mode" to adjust the settings.
- Via the menu item "Rooms in eco mode" you can determine in which rooms the temperature is to be lowered to eco temperature during eco mode. The eco mode can be activated by default for all rooms, which are heated by conventional or electric heaters. Rooms that are heated by a floor heating system only cannot be operated in eco mode. In this rooms, temperature reduction can be configured for a certain period using the holiday mode. You can deselect single rooms by deactivating the check box. Confirm your selection afterwards with "OK" (Android) or "Done" (iOS).
- Select the desired room temperature for the eco mode using the control dial in the menu item "Eco temperature". After tap on "Confirm" (Android) or "Done" (iOS) the selected temperature is saved.
- Use the menu item "Eco duration (for wall-mount remote control)" to determine the duration of the eco mode after pressing the wall-mount remote control. You can select between 2, 4 and 6 hours or "Permanent eco mode". Save your selection with "Confirm".

If you switch from automatic to the eco mode on the app homescreen, you will be asked automatically how long the eco mode has to be applied.

Via the slider, the following options are available:

- Off
- for 2 hours
- for 4 hours
- for 6 hours
- Date
- Permanent Eco mode



Figure 27: Screenshot eco duration via homescreen

In addition, you have the option to define a period of up to one year after tapping on the time limit for the duration of the eco mode.

7.4.2.2 Optimum start/stop function

If the optimum start/stop function is activated, the required lead time for heating or cooling a radiator or floor heating is calculated automatically. The set heating profile is calculated in advance on the basis of the heating times of the previous days. This offers the advantage that the desired room temperature is reached already at the set time in the heating profile and kept for the required period.

You can activate the optimum start/stop function as follows:

- Tap in the app homescreen on the main menu symbol and select "Climate control configuration" in the main menu.
- In the "Climate control configuration" menu, select "Optimum start/stop function".
- Activate the function by tapping on the radio button "On" (Android) or via the slider (iOS) and confirm your selection by tapping on "Confirm" (Android) or "Done" (iOS).

The app automatically returns back to the menu item "Climate control configuration". The function is then activated for conventional radiators or underfloor heating. In case of mixed installation, the function is activated for both systems at the same time. If you activate this function subsequently, please note that you must adapt your heating profiles accordingly.



Please note that the system "learns" the properties of your heating system in the first 2-3 days after activation of the optimum start/stop function. During this time, the temperature setting may be reached a few minutes earlier or later. Once this progress has been completed, you no longer need to consider any pre-heating or cooling phase for your heating profiles. However, if the optimum start/stop function is activated, the temperature may fall noticeably up to one hour before the cooling phase as set in the heating profile.

7.4.2.3 Humidity warning

Optimum humidity in living rooms has a positive effect on your well-being, protects the basic structure of the building and helps to prevent mould. The „Humidity warning“ function allows you to set individual threshold values for humidity in selected rooms. If the defined values are exceeded or not reached, a humidity warning appears on the homescreen of the Homematic IP app, optionally also as push notification on your smartphone. In addition, depending on the measured indoor humidity and the determined outdoor humidity (via a sensor for outdoor use or online weather data), you receive a recommendation as to whether you should ventilate or not in order to improve the indoor climate.

The humidity warning can also be used as trigger in automation, for example to activate a dehumidifier if a defined threshold value is exceeded. Proceed as follows to activate the humidity warning:

- Tap the main menu icon on the app homescreen and select „Climate control configuration“ from the main menu.
- Tap on „Humidity warning“.
- Tap on the + symbol in the following window and select a room for which you want

- to activate the humidity warning.
- The default humidity thresholds are 40% and 60%. If necessary, you can tap the room to adjust these values, which should apply to the selected room. In this window, you can also deactivate or activate the humidity warning at any time.
 - Repeat this procedure to select and configure additional rooms.
 - Then select the data source for the weather data. This can be one of the Homematic IP Weather Sensors, a Homematic IP Temperature and Humidity Sensor or an online data source.
 - Return to the previous overview to save the settings.

7.4.2.4 Whisper mode for radiator thermostats

This menu item can be used to set Homematic IP Radiator Thermostats to whisper mode if required. Activating this function is particularly useful in bedrooms, as opening and closing of valves in this mode is slower and therefore even more quiet.



Please note that the battery consumption of the respective radiator thermostat increases by approx. 15-20 % when whisper mode is activated.



Whisper mode is supported by the Homematic IP Radiator Thermostat (HmIP-eTRV/eTRV-2) and the Homematic IP Radiator Thermostat – compact (HmIP-eTRV-C).

Activate the whisper mode for radiator thermostats as follows:

- Tap the main menu icon on the app homescreen and select „Climate control configuration“ from the main menu.
- Tap on „Whisper mode“ and in the following window select the rooms for which the whisper mode is to be activated.



The rooms greyed out in the list do not support this function. Either there are no compatible thermostats in the corresponding room or there is a firmware update available for the radiator thermostats.

After tapping „OK“ (Android) or „Done“ (iOS), the selection is saved.

7.4.2.5 Heating failure alert

Your Homematic IP system is able to detect whether the desired target temperature has not been reached in at least one room within a period of 24 hours or whether no status info of the devices has been received from the room. This can indicate a failure of the heating system or a permanently open window. If you have activated the heating failure warning, you will receive a message on the homescreen of the Homematic IP app and a push message on your smartphone so that you can react accordingly.



Only rooms where radiator thermostats and/or wall thermostats are used are included in the monitoring for the heating failure warning.

Proceed as follows to activate the heating failure warning:

- Tap the main menu icon on the app homescreen and select „Climate control configuration“ from the main menu.
- Tap on „Heating failure warning“ and activate this function.
- After tapping „Confirm“ (Android) or „Done“ (iOS), the selection is saved.

7.5 Heating system control and hot water supply with HmIP-MIOB / HmIP-WHS2

With the Homematic Multi IO Box (HmIP-MIOB) or the Homematic IP Switch Actuator for Heating Systems - 2 channels (HmIP-WHS2), a smart heat demand control of the boiler can also be realised for installations with Homematic IP Radiator Thermostats and for mixed installations. In this case, the heat demand is determined via the radiator thermostats of one or more selected rooms or - depending on the configuration - via a room thermostat. Optionally, additional rooms with radiator thermostats can be integrated to determine the heat demand.



Please note that the latest firmware of the HmIP-MIOB or the HmIP-WHS2 is required. If you have already installed a Multi IO Box, please update the firmware.



Installation only by persons with relevant knowledge and experience with heating systems and electrical engineering!



Contact an electrical installer!

The following specialist knowledge is particularly important during installation:

- The „5 safety rules“ to be used: Disconnect from mains; Safeguard from switching on again; Check that system is de-energised; Earth and short circuit; Cover or cordon off neighbouring live parts;
- Select suitable tool, measuring equipment and, if necessary, personal safety equipment;
- Evaluation of measuring results;
- Selection of electrical installation material for safeguarding shut-off conditions;
- IP protection types;
- Installation of electrical installation material;
- Type of supply network (TN system, IT system, TT system) and the resulting connecting conditions (classical zero balancing, protective earthing, required additional measures etc.).

7.5.1 Application example 1: Heat demand control of the boiler

The functions and settings for heat demand control in connection with the Homematic IP Multi IO Box/Switch Actuator for Heating Systems are described below.

- Teach-in the Multi IO Box/Switch Actuator for Heating Systems. For further information, please refer to the operating manual of the device.
- In the main menu, tap “Device overview” and select the Multi IO Box/Switch Actuator for Heating Systems.
- Select a room in the menu item „Assignment“ and change the device name if necessary.
- You will be directed to the device configuration in the next window.



The connection of this device, as well as the assignment to a function in the app and the configuration may only be carried out by a specialist.

7.5.1.1 Heating system control for heat demand - without leading room

With this option, the radiator thermostats of one or more selected rooms provide the data for the heat demand control of the boiler. Only those rooms should be selected that are relevant for determining the heat demand in terms of size and use.

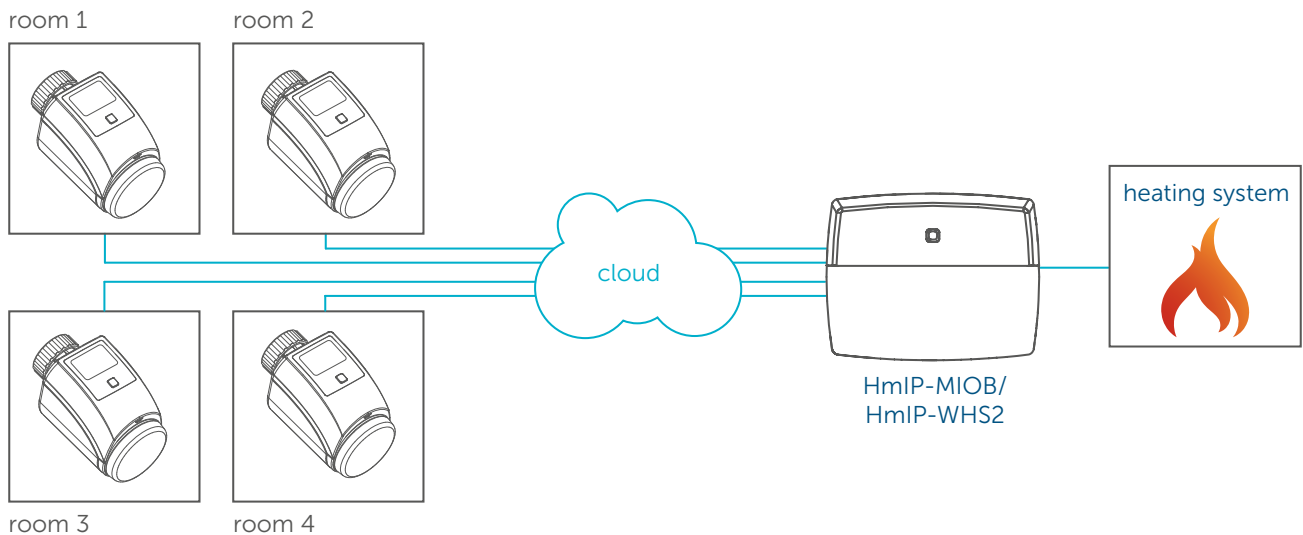

- Tap on „1 - OUT (4.1./4.2)“ and confirm the notification in the following pop-up window.
- In the „Assignment“ menu item, assign output 1 - OUT (4.1./4.2) to the „Heat demand for rooms“ function and tap „Continue“.

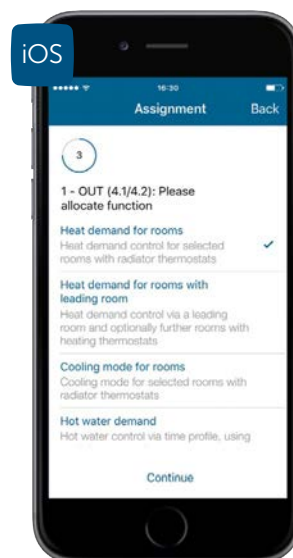

- After tapping „Continue“ again and then tapping „Done“, you will reach the configuration menu.
- Tap on „Rooms for heat demand determination“, select the relevant rooms and tap on „OK“ (Android) or on „Done“ (iOS).

Via the menu item „Minimum valve opening for heat demand“ you determine the valve opening

degree in percent from which a heat demand is detected. A value of 1 % is preset. You should only increase this value if the valve only opens at a higher value or allows a noticeable water flow. For further information, please contact your plumbing and heating installer.

To change the value, please proceed as follows:

- Tap on „Minimum valve opening for heat demand“, select the desired value using the rotary control and tap on „Confirm“ (Android) or on „Done“ (iOS).



Increasing the value can lead to larger fluctuations in the room temperature.

Use the “Time until activation of emergency mode” menu item to define the period for which the last determined heat demand should remain constant in the event of a failure of the cloud connection. Emergency operation is not activated until the selected period has elapsed and without a signal from the cloud (e.g. in the event of an Internet failure) (see below). The default setting is a period of 30 minutes.

- Tap on „Time until activation of emergency mode“, select the desired duration in minutes and tap on „OK“.

The „Emergency operation“ menu item is used to define the switch-on and switch-off times of the output in emergency operation. If there is a loss of connection to the cloud, it can be ensured that heat demand is signalled to the heat generator during certain intervals in order to avoid excessive cooling of the building. Here you have the following options:

- Permanently off: If this option is selected, the boiler is switched off permanently.
- Permanently on: If this option is selected, the boiler is permanently switched on.
- Individual times: Here you can define individual times for the on and off periods (in minutes).

7.5.1.2 Heating system control for heat demand – with leading room

If a leading room is selected for the heat demand determination, the room thermostat of the leading room determines the heat demand. This can therefore also be a room equipped with floor heating.

One advantage of this variant is that, thanks to a direct link between the room thermostat of the leading room and the Multi IO Box, the heat demand control of the boiler remains active even in the event of an Internet failure. If other rooms with radiator thermostats are selected in addition to the leading room, these are not taken into account in the event of an Internet failure.

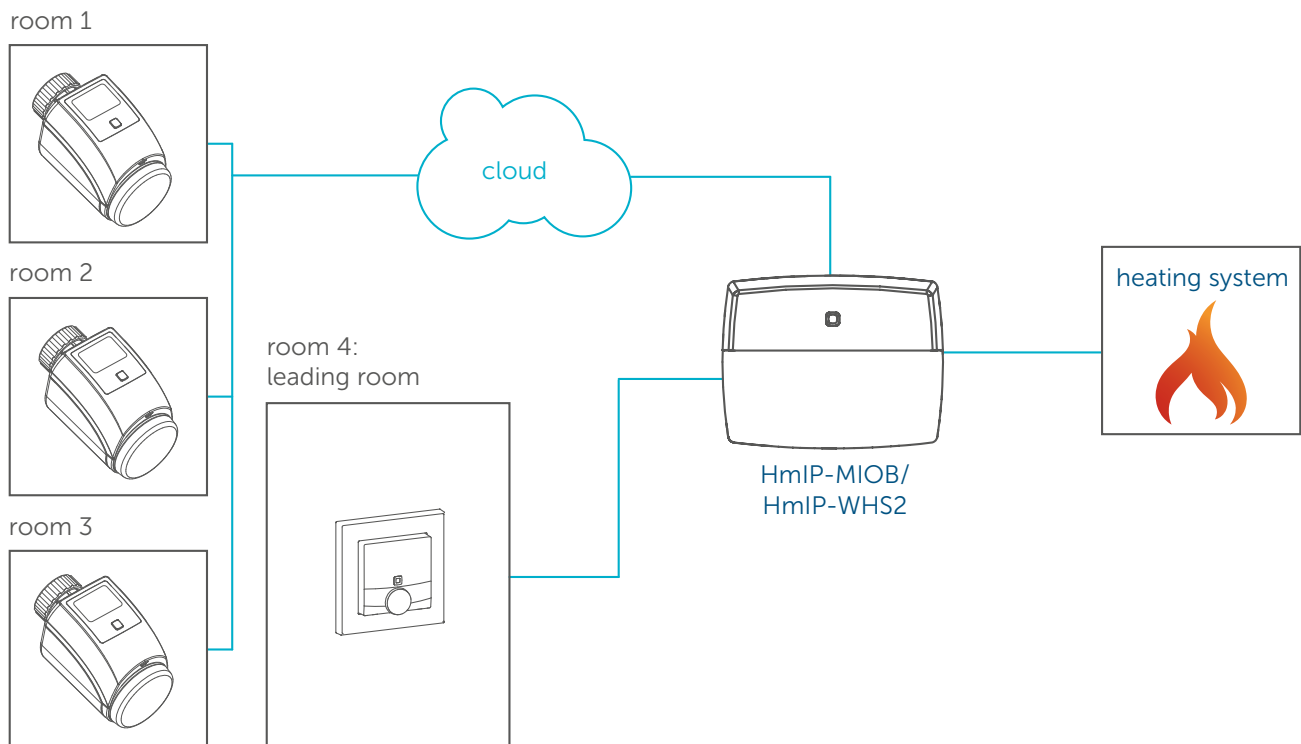

In this case, proceed as follows:

- Tap on „1 - OUT (4.1./4.2)” and confirm the notification in the following pop-up window.
- In the „Assignment” menu item, assign output 1 - OUT (4.1./4.2) to the „Heat demand for rooms with leading room” function and tap „Continue”.

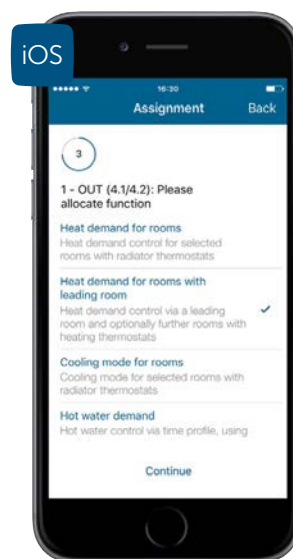

- After tapping „Continue” again and then „Done”, you reach the configuration menu.
- Tap on „Leading room” and select the leading room for the heat demand control of your boiler. This is usually the room in which you spend most time, for example the living room.

- Tap on „Rooms for heat demand determination“, select the rooms (e.g. bathroom) that you also want to select for heat demand control and tap on „OK“. This function is optional.
- If necessary, adjust the valve opening level above which heat demand is detected.
- The menu items „Maximum follow-up time“ and „Emergency operation“ are not relevant in this variant, as thanks to the direct link, heat demand control via the room thermostat of the leading room is ensured even in the event of a failure of the cloud connection.

7.5.1.3 Control of the cooling mode of the heating system – without leading room

If the boiler has a connection for external control of the energy saving mode, the energy saving mode of the boiler is automatically activated when the radiator thermostats of selected rooms transmit a heat demand that is correspondingly low.

- In the „Assignment“ menu item, assign the output (1 – OUT or 2 – OUT) that you have selected for the external control of the energy saving mode of the boiler to the „Cooling mode for rooms“ function and tap „Continue“.

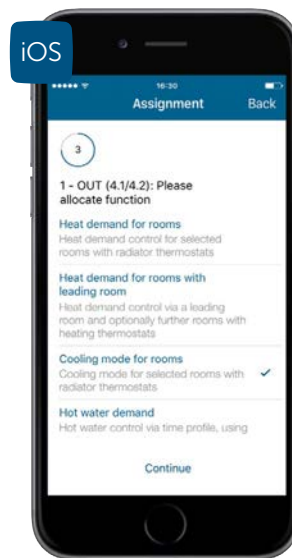

- After tapping „Continue“ again and then tapping „Done“, you will reach the configuration menu.
- After tapping on „Rooms for heat demand determination“, select the rooms that are to be considered for the heat demand determination and tap on „OK“ to confirm.

If necessary, settings for the „Minimum valve opening for heat demand“, the „Time until activation of emergency mode“ or the switch-on and switch-off times of the output in emergency operation can be adjusted (see section „Heat demand for rooms“).

7.5.2 Application example 2: Hot water supply

With this menu item you have the possibility to control your hot water demand – similar to the heating profiles – via a hot water supply profile. In addition, you can use a wall switch to activate the hot water supply as required (boost function) or deactivate the time profile for hot water supply.

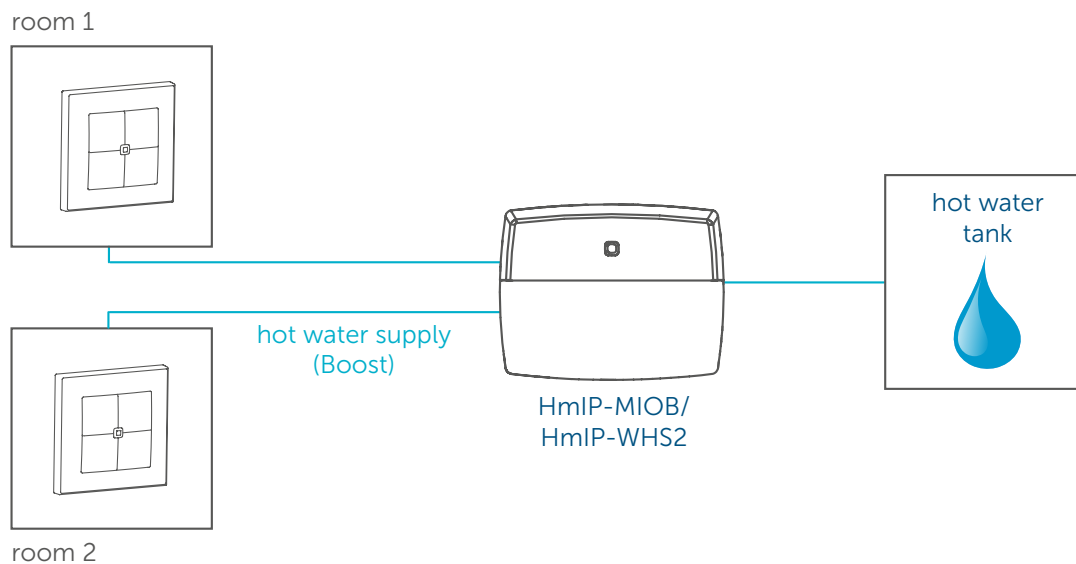

7.5.2.1 Hot water profile

To create a hot water profile, please proceed as follows:

- Select the Multi IO Box or the switching actuator for heating systems in the device overview. In the „Assignment“ menu item, assign output 2 - OUT (5.1./5.2/5.3) to the „Hot water supply“ function and press „Continue“.

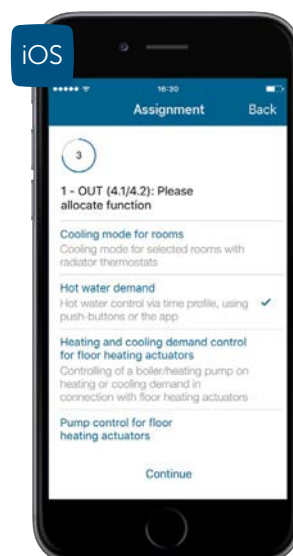

- After tapping „Continue“ again, the data is transmitted to the Multi IO Box or switching actuator for heating systems.
- In the main menu under „Climate control“, tap on „Hot water configuration“ and then on „Hot water profile“. This takes you to the „Hot water supply“ menu.
- Tap on the + symbol at the bottom right of the screen.

You can select between the following options here:

Switching time

This menu item allows you to define different switch-on and switch-off times for hot water supply at each day of the week.

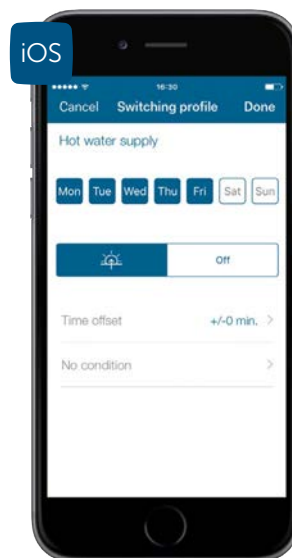

In the following example, the hot water supply is to be activated for 2 hours each morning and evening – for the weekdays and Saturday/Sunday at different times.

To do this, proceed as follows:

- Under „Selection switching time“, select the menu item „Switching time“ (already preset) and tap on „Confirm“.
- Select the weekdays MO-FR (already preset).
- Select the time at which hot water supply is to be activated, tap „Off“ and select „On“.
- After tapping on the left arrow at the top left of the screen or „Done“, the switching time is saved.
- Tap the + symbol at the bottom right of the screen again and select „Switching time“.
- Specify the time at which the hot water heating is to be deactivated.
- After tapping on the left arrow at the top left of the screen or „Done“, the switching time is saved.

According to these instructions, select the on and off points for morning and evening, for example from 6:00 to 8:00 and from 19:00 to 22:00 and then configure the on and off points for SA/SO.

Sunrise/sunset

Here you can define the switching times for your hot water supply depending on the sunrise or sunset, with or without a time offset and additionally under the condition „Not earlier than/ not later than“.

The following is an example of how hot water demand is controlled depending on the sunrise.

- In the main menu of the Homematic IP App under „Climate control“, tap on „Hot water configuration“ and then on „Hot water profile“. This takes you to the „Hot water supply“ menu.
- Tap on the + symbol at the bottom right of the screen.
- Select the „Sunrise“ option and tap on „Confirm“.
- Tap „Off“, select „On“ and then tap the „Sunrise“ icon.
- By tapping on „Sunrise“, you can set a time offset to the sunrise if required, for example + 60 minutes.
- If you tap on „No condition“, you can also use the „Not earlier than“ or „Not later than“ selection to specify a point in time at which the hot water supply should start at the earliest or at the latest, for example at 6:00 a.m. at the earliest.

7.5.2.2 Controlling the hot water supply via a wall-mount remote control

If you integrate a suitable transmitter (e.g. a wall-mount remote control) into your Homematic IP system, e.g. a Homematic IP Wall-mount Remote Control - 6-buttons, you can control the hot water supply via the remote control in addition to the time profile.

To configure the wall-mount remote control, please proceed as follows:

- Select your wall-mount remote control via the main menu in the device overview and tap on „Assignment“.
- Select a room, tap „Continue“ and adjust the device name if necessary.
- Tap on „Continue“, select a pair of buttons and tap on „Climate control“.
- After tapping „Continue“, you can assign the desired function to the pair of buttons:

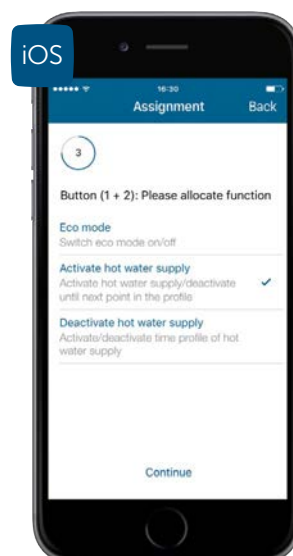

Start/stop hot water supply

This function enables you to activate hot water supply (boost function) or deactivate it until the next profile time at the touch of a button.

- Tap on „Start/stop hot water supply“ and then on „Continue“. After tapping „Continue“ again, the data will be transmitted.

Activate/deactivate hot water supply

This function enables you to activate hot water supply (boost function) or deactivate it until the next profile time at the touch of a button.

- Tap „Activate/deactivate hot water supply“ and afterwards on „Continue“. Tap „Continue“ again to transmit the data.

7.6 Floor heating control

With the integration of floor heating actuators into your system you can comfortably configure and control your floor heating and other water based surface heatings in connection with one or more Homematic IP Wall Thermostats via the Homematic IP app. In addition, several floor heating actuators can be used in the house and integrated into the Homematic IP system.

The Homematic IP Wall Thermostat with switching output – for brand switches offers a relay or triac output for controlling existing 230 V or 24 V floor heating valve drives. By controlling the output, the room temperature is regulated according to your individually defined heating profiles. You can simply replace the existing wall thermostat of your installation by the Homematic IP Wall Thermostat and install the device in the flush-mounted box.

The Homematic IP floor heating control can be realised using floor heating actuators as well as one or more Homematic IP Wall Thermostats (depending on the number of rooms equipped with floor heating). Homematic IP Floor Heating Actuators are available in four different versions, each for 6 (HmIP-FAL230-C6 and HmIP-FAL24-C6) or 10 (HmIP-FAL230-C10 and HmIP-FAL24-C10) heating zones. The devices require either 24 or 230 Volt for power supply.

The wall thermostat can be operated either using batteries (HmIP-WTH-2) as well as 230 V or 24 V supply voltage for installation into existing flush-mounted boxes (HmIP-BWTH and HmIP-BWTH24).

You can control standard floor heating systems with 6 or 10 heating zones using the Homematic IP Floor Heating Actuators. This has to be connected directly to heating zone 1 (HZ1) of the floor heating actuator.

In connection with the Homematic IP Multi IO Box, additional functions and devices can be integrated. This includes e.g. humidity and temperature limiting functions, external timers as well as switching from heating to cooling operation for floor heating system with cooling function.

7.6.1 Options for controlling the floor heating system

Configuration and operation of existing valve drives via wall-thermostat with switching output – for brand switches

- Easy upgrading of conventional floor heating control systems to an intelligent regulation of the room temperature
- Individual control of 230 V and 24 V valve drives for floor heating systems via relay or triac output

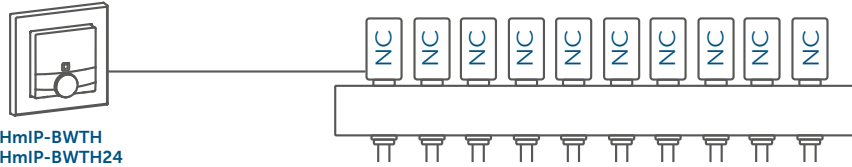

Configuration and operation of floor heating actuators via wall-thermostat

- Floor heating actuator is wirelessly connected to the wall-thermostat and configured via this device
- Regulation of the room temperature is done only locally via the wall-thermostat

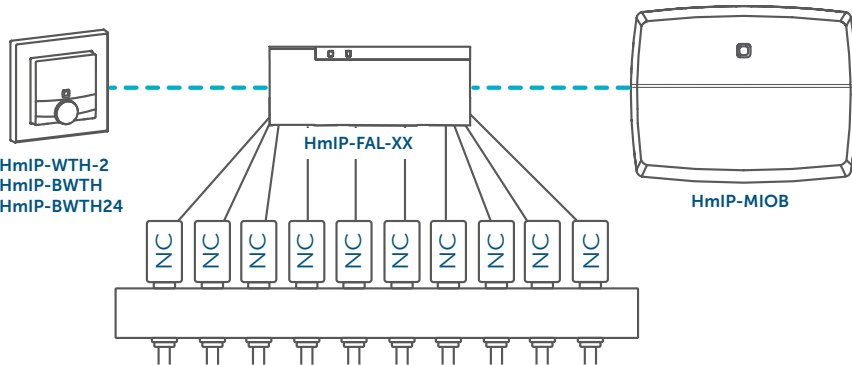

Configuration and operation via app

- For operation with the Homematic IP Access Point, setup, configuration and temperature settings are comfortably carried out via the Homematic IP smartphone app
- Demand-based regulation of the temperature in rooms with floor heating and conventional radiators can take place simultaneously

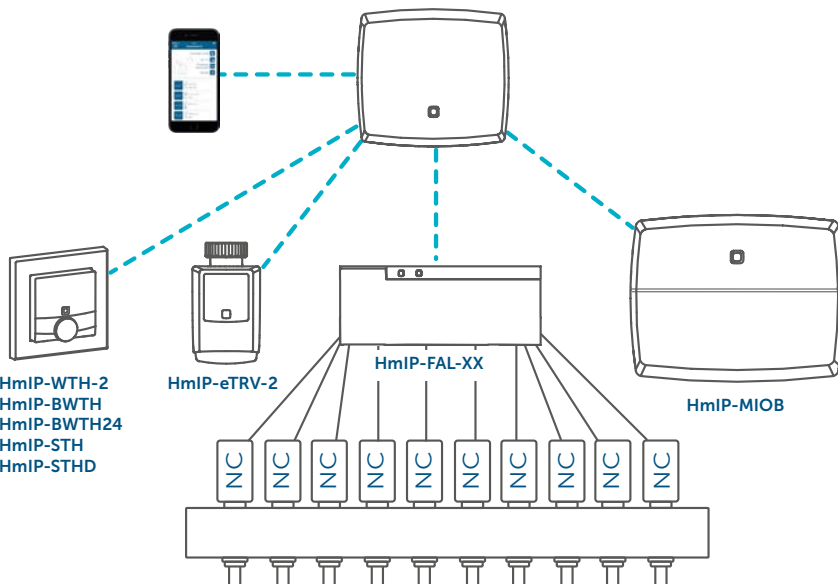

--- radio connection
— wired connection

7.6.2 Set-up and configuration via wall thermostats (stand-alone without Access Point)

7.6.2.1 Teaching-in

If you use the floor heating actuator in a stand-alone solution together with one or more Homematic IP Wall Thermostats (HmIP-WTH-2, HmIP-BWTH and HmIP-BWTH24), the configuration and temperature control are performed via the wall thermostat only. Therefore, the single channels of the floor heating actuator are paired to the wall thermostat(s).

To do this, proceed as follows:

- Select the channel for pairing a device by pressing the "Select" button of the floor heating actuator briefly. Press once for channel 1, twice for channel 2 etc. The channel LED lights permanently for the corresponding channel.
- Press and hold down the system button of the actuator for 4 s until the LED quickly starts flashing orange. The pairing mode of the selected channel remains activated for 3 minutes.
- Press and hold down the system button of the wall thermostat for at least 4 seconds to activate the pairing mode. The device LED flashes orange.

The device LED of the selected channel lights up green to indicate that pairing has been successful. If pairing failed, the device LED lights up red. Please try again.

If several heating circuits are installed in one room, repeat the pairing procedure for all channels that control the valve drives for the single heating circuits of the room. Repeat this procedure for all other rooms.

7.6.2.2 Application of several floor heating actuators

To add a new floor heating actuator to the system or to the existing devices, please proceed as follows:

- First pair the new floor heating actuator with an existing one. Activate the pairing mode of the existing floor heating actuator. Therefore, press and hold down the system button for at least 4 seconds.
- Activate the pairing mode of the new floor heating actuator. Press and hold down the system button for at least 4 seconds. The device LED lights up green to indicate that pairing has been successful. If pairing failed, the device LED lights up red. Please try again.
- You can add the new floor heating actuator to other Homematic IP devices such as the wall thermostat or the Multi IO Box. Simply activate the pairing mode of the floor heating actuator first and of the device you want to pair afterwards. For further information, please refer to the user manual of the corresponding device.



For pump control it is important to pair the floor heating actuators with one another.

7.6.2.3 Communication test

You can check the radio connection between your Homematic IP Wall Thermostat and the Homematic IP Floor Heating Actuator as well as the correct allocation of channels.

During this check, the wall thermostat sends a switching command to the floor heating actuator. The wall thermostats allocated to the heating circuit(s) are triggered and switched on or off for one minute, depending on the system status. Meanwhile, the corresponding channel LEDs of the floor heating actuator light up green.

- Press and hold down the control wheel of the wall thermostat to open the configuration menu.
- Select the  icon by turning the control wheel and confirm by pressing the control wheel briefly.

7.6.2.4 Configuration via Wall Thermostat

The Homematic IP Floor Heating Actuator is pre-configured in that way that it is not necessary to change the configuration settings after teaching-in. In certain cases and for certain requirements there is a wide range of configuration possibilities available via the Homematic IP Wall Thermostat.

To configure the floor heating actuator via the wall thermostat, please proceed as follows:

- Press and hold down the control wheel of the wall thermostat to open the configuration menu.
- Select the **"FAL"** symbol by turning the control wheel and confirm by pressing the control wheel briefly.
- If the wall thermostat is connected to more than one floor heating actuator, please select the required floor heating actuator using the control wheel.
- Please define if you want to configure the device parameters ("UnP1/UnP2") or the channel parameters ("ChAn").



All the settings that are made under "UnP1/UnP2" will be applied to the entire device. All settings that are made under "ChAn" will be applied to the single channels of the device.

Device parameter UnP1

Here you can adjust the configuration of the device parameters. The index numbers indicate a unique description for different parameters.

- **Index P024: Frost protection temperature**
The default value is 16. At this value, the floor heating actuator is set to a room temperature of 8 °C as setpoint value to avoid freezing of the system.
If required you can adjust the values between 3 (protection deactivated) and 20 (10 °C) in 0.5 °C steps.

Parameter	Index	Value	Meaning
Frost protection temperature	P024	3	Frost protection activated
		4	2.0 °C
		5	2.5 °C
		16	8.0 °C (default)
		19	9.5 °C
		20	10.0 °C

- **Index P025: Pump control**

For evaluating the parameters, the following terms are important:

- Pump control activated:
Select one of the values 0-3 if a heating pump is connected directly to heating zone 1 (HZ1) of the actuator.
- Pump control deactivated:
Select one of the value 4-7 if you want to use the heating pump of your heating system.
- Load balancing:
When selecting a value with load balancing the heating zone will be controlled in a staggered way to provide continuous flow of heating water - depending on the pump control 0 – 1 (pump active) or 4 – 5 (pump inactive).
- Load collection:
When selecting a value with load collection, all heating zones are controlled collectively (if possible) – depending on pump control 2 – 3 (pump active) or 6 – 7 (pump inactive)
- Valve type:
If valve drives of the type "normally closed" (NC) are installed in your heating manifold, select one of the values in accordance with your requirements (value 0 or 2 for active pump control or value 4 or 6 for inactive pump control).
- If valve drives of the type "normally open" (NO) are installed in your heating manifold, select one of the values in accordance with your requirements (values 1, 3, 5 or 7, depending on the pump control and load balancing).

Parameter	Index	Value	Meaning
Pump control activated/deactivated	P025	0	Pump control activated Load balancing NC
Load balancing Load collection		1	Pump control activated Load balancing NO
Valve type (NO/NC)		2	Pump control activated Load collection NC
		3	Pump control activated Load collection NO
		4	Pump control deactivated (default) Load balancing NC
		5	Pump control deactivated Load balancing NO
		6	Pump control deactivated Load collection NC
		7	Pump control deactivated Load collection NO

- **Index P026: Emergency operation in heating mode**

The valve opening duration is recalculated every 15 minutes. If the radio communication between the wall thermostat and the floor heating actuator fails for a longer period of time, e.g. if a battery is empty, all valves are controlled automatically. In the default settings, the valve is opened for 225 seconds (25 % for 15 minutes). When the radio communication is recovered the system changes back to normal operation.

Parameter	Index	Value	Meaning
Emergency operation in heating mode	P026	0	0 % (0 seconds)
		1	1 %
		25	25 % (default)
		99	99 %
		100	100 % (15 minutes)

- **Index P032: Emergency operation in cooling mode**

If the radio communication between the wall thermostat and the floor heating actuator fails for a longer period of time, the cooling mode is deactivated or the valve changes back to a defined value.

Parameter	Index	Value	Meaning
Emergency operation in cooling mode	P032	0	0 % (default)
		1	1 %
		99	99 %
		100	100 %

Device parameter UnP2

- **Index P007: Duration of valve protection function**

In time periods without temperature regulation, e.g. during summer, the valve drives are triggered regularly to prevent the valve from sticking. Here, you can adjust the duration for triggering.

Parameter	Index	Value	Meaning
Interval time valve protection function	P007	128	0 minutes
		129	1 minute
		133	5 minutes (default)
		138	10 minutes

- **Index P051: Interval time for valve protection function**

Here, you can define the interval for activating the valve protection function.

Parameter	Index	Value	Meaning
Interval time for valve protection function	P051	224	0 days
		225	1 day
		238	14 days (default)
		251	27 days
		252	28 days

Channel parameter ChAn

In this menu item you can adjust the settings for the single channels of your floor heating actuator, if required.

- **Index P006: Pump lead time**

The adjustment of parameters is only possible for a heating pump that is directly connected to heating zone 1 (HZ1) of the floor heating actuator.

Here, you can adjust the pump lead time, which is the time between the request of a switching output until the pump is switched on.

Parameter	Index	Value	Meaning
Pump lead time	P006	128	0 minutes
		129	1 minute
		130	2 minutes (default)
		147	19 minutes
		148	20 minutes

- **Index P007: Duration/length of pump protection function**

The adjustment of parameters is only possible for a heating pump that is directly connected to heating zone 1 (HZ1) of the floor heating actuator.

To avoid damages to the pump while it is not used during a longer period of time, the heating pump is switched cyclically. Here, define the length/duration of the pump protection function.

Parameter	Index	Value	Meaning
Duration/length of pump protection function	P006	128	0 minutes
		129	1 minute
		133	5 minutes (default)
		138	10 minutes

- **Index P008: Pump follow-up time**

The adjustment of parameters is only possible for a heating pump that is directly connected to heating zone 1 (HZ1) of the floor heating actuator.

Here, you can adjust the pump follow-up time, which is the time between the request of a switching output until the pump is switched off.

Parameter	Index	Value	Meaning
Pump follow-up time	P008	128	0 minutes
		129	1 minute
		130	2 minutes (default)
		147	19 minutes
		148	20 minutes

- **Index P045: Minimum floor temperature**

This function is only available in connection with a floor temperature sensor (currently not yet available).

Here, you can define the threshold of the floor temperature for activating the floor heating if the value falls below.

Parameter	Index	Value	Meaning
Minimum floor temperature	P045	10	5.0 °C
		11	5.5 °C
		38	19.0 °C (default)
		59	29.5 °C
		60	30.0 °C

- **Index P050: Humidity limit**

When using a Homematic IP Multi IO Box with connected dehumidifier, the humidity value from which the dehumidifier is activated in order to avoid condensation problems can be set here. In case of floor heating systems with active cooling operation, the corresponding cooling circuit is also closed to avoid further humidity condensation.

Parameter	Index	Value	Meaning
Humidity limit	P045	40	40 %: humidity limit deactivated
		80	80 %: humidity limit deactivated
		168	40 %: humidity limit activated
		188	60 %: humidity limit activated (default)
		208	80 %: humidity limit activated

- **Index P051: Time interval of pump protection function**

The adjustment of parameters is only possible for a heating pump that is directly connected to heating zone 1 (HZ1) of the floor heating actuator.

To avoid damages to the pump while it is not used during a longer period of time, the heating pump is switched cyclically. Here you can adjust the interval for activation of the pump protection function, if required.

Parameter	Index	Value	Meaning
Time interval for pump protection function	P051	225	1 day
		226	2 days
		238	14 days (default)
		251	27 days
		252	28 days

- **Index P052: Cooling in cooling mode activated/deactivated**

Here, you can activate or deactivate the cooling function for single channels (heating zones) if required.

Parameter	Index	Value	Meaning
Cooling in cooling mode	P052	0	Cooling in cooling mode deactivated
		1	Cooling in cooling mode activated (default)

- **Index P053: Heating in heating mode activated/deactivated**

Here, you can activate or deactivate the heating function for single channels (heating zones) if required.

Parameter	Index	Value	Meaning
Heating in heating mode	P053	0	Heating in heating mode deactivated
		1	Heating in heating mode activated (default)

- **Index P054: Selection of heating system**

In this menu item you can adjust the floor heating in connection with additional heating sources in the room where the floor heating circuit is controlled via the selected channel.

Parameter	Index	Value	Meaning
Configuration for rooms	P054	0	Standard room (default)
		1	Room with fireplace
		2	Room with towel rail heating

- **Index P055: Selection of heating system**

Here you can select your heating system in case of special conditions:

- Standard floor heating (default):
Standard floor heating in conventional buildings
- Low energy floor heating:
Floor heating with a very low flow temperature
- Radiator:
For controlling water-based radiators
- Passive convector:
Rooms with underfloor convectors
- Active convector:
Rooms with fan coils

Parameter	Index	Value	Meaning
Selection of heating system	P055	0 1 2 3 4	Standard floor heating (default) Low energy floor heating Radiator Passive convector Active convector



The Homematic IP Wall Thermostat with switching output (HmIP-BWTH / HmIP-BWTH24) additionally offers the menu item "SET". In this menu item you can select the valve type (normally closed or normally open) that is connected to the switch relay as well as your domestic heating system. For further information, please refer to the user manual of the device.

7.6.3 Set-up and configuration via the Homematic IP app

If you are using a Homematic IP Floor Heating Actuator in connection with a Homematic IP Access Point, teaching-in and configuration are performed via the app.



First, set up your Homematic IP Access Point via the Homematic IP app to enable operation of other Homematic IP devices within your system. For further information, please refer to the operating manual of the Access Point.

7.6.3.1 Teaching-in of the wall thermostat



For controlling the floor heating actuator, one or more Homematic IP Wall Thermostats are necessary for operation. The wall thermostat requires at least the firmware version 1.6. For further information about the device firmware please refer to section "14.3.1 Device software update (OTAU)".

To teach-in your wall thermostat to the Access Point, please proceed as follows:

- Open the Homematic IP app on your smartphone.
- Select the menu item "Teach-in device".
- To remove the electronic unit from the frame, take hold of the sides and pull it out.
- Turn over the electronic unit.
- Remove the insulation strip from the battery compartment of the wall thermostat.
- Pairing mode remains activated for 3 minutes.



You can manually start the teach-in mode for another 3 minutes by pressing the system button shortly.

- Your device will automatically appear in the Homematic IP app.
- To confirm, please enter the last four digits of the device number (SGTIN) in your app or scan the QR code. Therefore, please see the sticker supplied or attached to the device.
- Please wait until teach-in is completed.
- If teaching-in was successful, the LED lights up green. The device is now ready for use.
- If the LED lights up red, please try again.

- Select the desired solution for your device.
- Allocate the device to a room and give the device a name.



One wall thermostat can be connected to a maximum number of two floor heating actuators and 10 heating zones.

7.6.3.2 Teaching-in the floor heating actuator

To teach-in your floor heating actuator to the Access Point, please proceed as follows:

- Open the Homematic IP app on your smartphone.
- Select the menu item "Teach-in device".
- Briefly press the system button of the actuator until the LED quickly starts flashing orange. The teach-in mode of the floor heating actuator remains activated for 3 minutes.



You can manually start the teach-in mode for another 3 minutes by pressing the system button shortly.

- Your device will automatically appear in the Homematic IP app.
- To confirm, please enter the last four digits of the device number (SGTIN) in your app or scan the QR code. Therefore, please see the sticker supplied or attached to the device.
- Please wait until teach-in is completed.
- If teaching-in was successful, the LED lights up green.
- If the LED lights up red, please try again.
- Allocate the floor heating actuator to the room, where it is installed and tap "Continue".
- Enter a device name and tap "Continue".
- Configure the functions of the single heating circuits. Therefore, tap on the single heating circuits and allocate them to the rooms, that are heated via this heating circuits.



Please note that one room can be supplied also via several heating circuits. For further information, please contact your plumbing and heating installer.

- Tap "Continue" and afterwards on "Done". You are directed to the "Device configuration" window.



In the first 10 minutes, the start mode is activated. All heating zones and the device LED light up green.

In the following 20 minutes, the setup-mode is active. The heating zones are controlled via a two-point control response, i.e. that as soon as the setpoint temperature is reached, the heating zone will be switched off. If the temperature falls below the setpoint temperature, the heating zone is switched on.

After 30 minutes, the standard operation is active. Then, the valves are controlled via PI regulation with PWM cycle.

7.6.3.3 Definition of terms for floor heating control

The Homematic IP Floor Heating Actuator is pre-configured in that way that it is not necessary to change the configuration settings after teaching-in. If required, you can still change different parameters via this menu.



Further information about the definitions regarding floor heating control can be found in the "Glossary" on page 203.

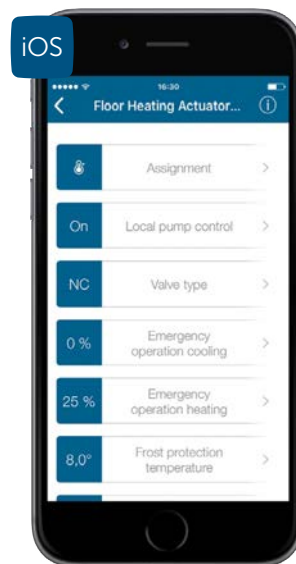

Figure 28: Screenshot device configuration floor heating actuator

Assignment

Here, you can subsequently change the room allocation of the device, the device name as well as the assignment of heating circuits.

Local pump control

In the default settings, the local pump control is deactivated, i.e. that the integrated pump of your heating system takes care of the circulation. If a heating pump is directly connected to the floor heating actuator via heating zone 1 (HZ1), activate the local pump control.

- Tap "Local pump control".
- Tap "On" and confirm.

Valve type

Usually, in your heating manifold valve drives of the valve type "normally closed" (NC) are installed. This complies with the default settings.

If valve drives of the valve type "normally open" are installed in your manifold, please select the option "normally open" (NO). For further information, please contact your plumbing and heating installer.

Pump lead time/pump follow-up time

In case of activated local pump control - i.e. a pump is connected directly to the floor heating actuator - you can adjust a switch on or switch off delay of 0 to 20 minutes in 2 minutes steps for the heating pump if required.

Emergency operation cooling

If the radio communication between the wall thermostat and the floor heating actuator fails for a longer period of time, the cooling mode is deactivated or the valve changes back to a defined value. In the default settings, a reduction of the cooling mode to 0 % is set.

Emergency operation heating

The valve opening duration is recalculated every 15 minutes. If the radio communication between the wall thermostat and the floor heating actuator fails for a longer period of time, e.g. if a battery is empty, all valves are controlled automatically. In the default settings, the valve is opened for 225 seconds (25 % for 15 minutes). When the radio communication is recovered the system changes back to normal operation.

Frost protection temperature

To avoid freezing of the system, the floor heating actuator is regulated to a room temperature of 8 °C as setpoint value (default). If required, you can use the control dial to deactivate the frost protection ("Off") or to select a room temperature between 2 °C and 10 °C in 0.5 °C steps.

Heating zone control

When selecting "Load balancing" (default), the heating zone will be controlled in a staggered way (if possible), to provide continuous flow of heating water.

When selecting "Load collection", the heating zones are controlled collectively (if possible).

Valve protection function

Thanks to the valve protection function, in time periods without temperature regulation, e.g. during summer, the valve drives are triggered regularly to prevent the valve from sticking.

Here, you can define the time interval (off, 1-28 days) as well as the duration for triggering (0-10 minutes).

Information about the Multi IO Box

The analogue output 0-10 V is currently available only in connection with the Homematic Central Control Unit CCU2/CCU3.

7.6.4 Application examples

Thanks to the comprehensive portfolio of different Homematic IP components for controlling your floor heating, you can make individual changes and adjust the system to the structural conditions in your home.

In the following sections you will find different application examples for the installation as well as for the different fields of application.

7.6.4.1 Application example 1: Floor heating control

After connecting the floor heating actuator as well as one or more Homematic IP Wall Thermostats, the single channels of the floor heating actuator have to be connected to the wall thermostat of the room that is supplied via the corresponding heating zone or heating circuit. The heating circuits 1-6 as well as 1-10 are connected via the Homematic IP Wall Thermostat. For controlling the floor heating, several floor heating actuators can be used.

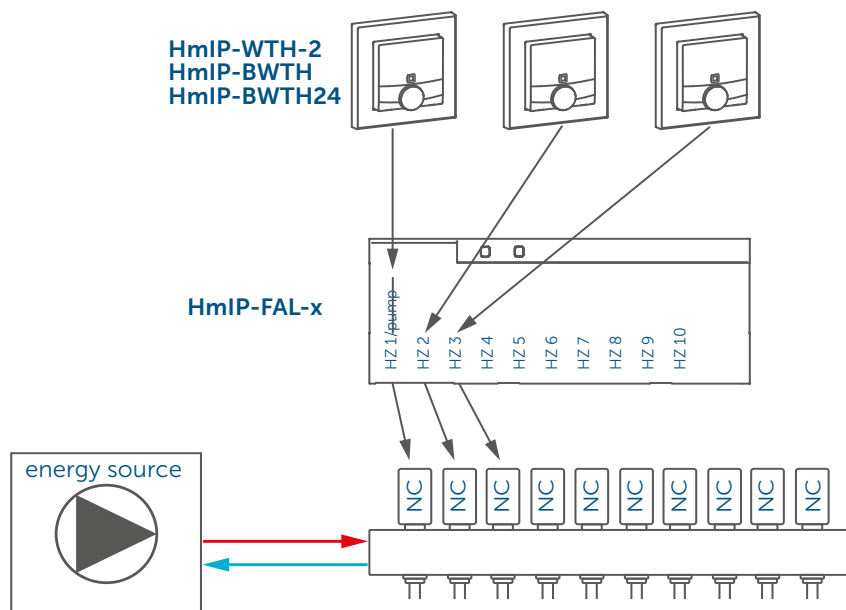

You can adjust the configuration of devices for floor heating control as shown in the screenshots below:

- Teach-in the floor heating actuator and assign every channel to a room.
- In the menu, tap "Device overview" and select the floor heating actuator.

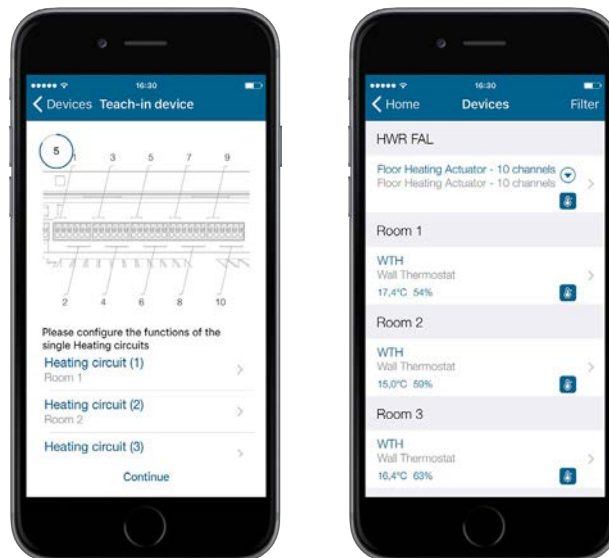

Figure 29: Screenshot teaching-in and selecting HmIP-FAL-xx

- You will be directed to the device configuration in the next window.

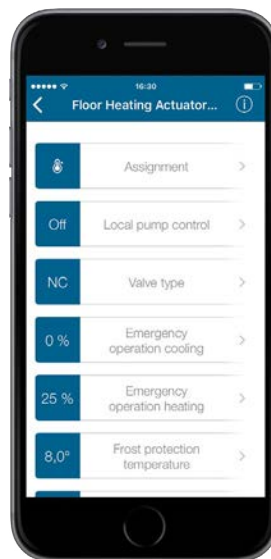

Figure 30: Screenshot configuration HmIP-FAL-xx

- Set the local pump control to "Off" and adjust the valve type to the variant used in your installation (NC or NO).
- Additional settings can be adjusted by selecting the corresponding room.

7.6.4.2 Application example 2: Floor heating and heating pump control

When using a floor heating actuator you can also control an additional heating pump. In this case, heating circuit 1 only controls the heating pump.

The heating circuits 2-6 as well as 2-10 are connected via the Homematic IP Wall Thermostat. For controlling the floor heating, several floor heating actuators can be used.



It is sufficient to connect any wall thermostat with the channel of the floor heating actuator that controls the pump in order to ensure heat demand regulation for all rooms.

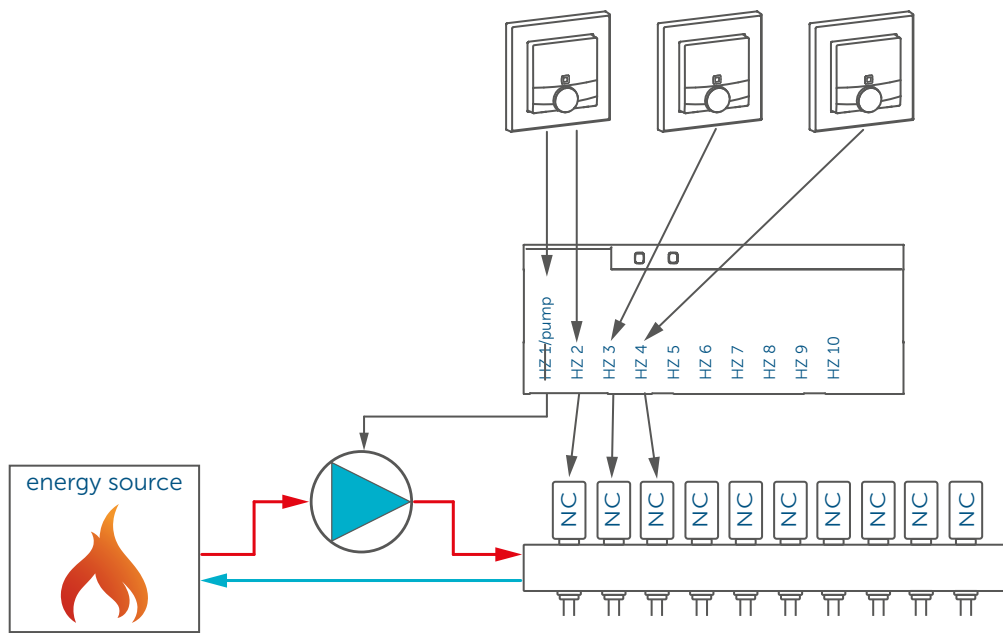

You can configure the devices for controlling the floor heating and the heating pump as follows:

- Teach-in the floor heating actuator and assign every channel to a room.
- In the menu, tap "Device overview" and select the floor heating actuator.
- You will be directed to the device configuration in the next window.

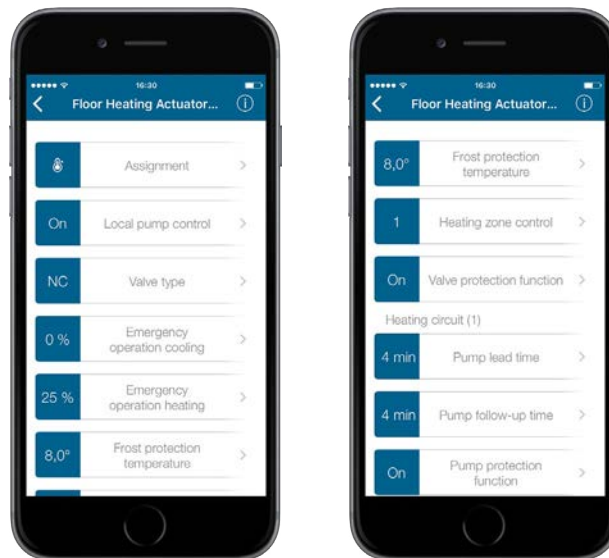

Figure 31: Screenshot configuration HmIP-FAL-xx for pump control

- Set the local pump control to “On” and adjust the valve type to the variant used in your installation (NC or NO), if required.
- Under “Heating circuit” you can configure the pump lead time and the pump follow-up time (see sec. „Pump lead time/pump follow-up time” on page 90).
- Additional settings can be adjusted by selecting the corresponding room.

7.6.4.3 Application example 3: Floor heating, boiler and dehumidifier control

When using a floor heating actuator and a Multi IO Box you can control a connected boiler as well as a dehumidifier.

The boiler control is performed via the output OUT1 of the Multi IO Box.

A dehumidifier is controlled via the output OUT2 of the Multi IO Box. The current humidity is measured by the Homematic IP Wall Thermostat.

The inputs of the Multi IO Box are not switched.

The heating circuits 1-6 as well as 1-10 are connected via the Homematic IP Wall Thermostat.

For controlling the floor heating, several floor heating actuators can be used.

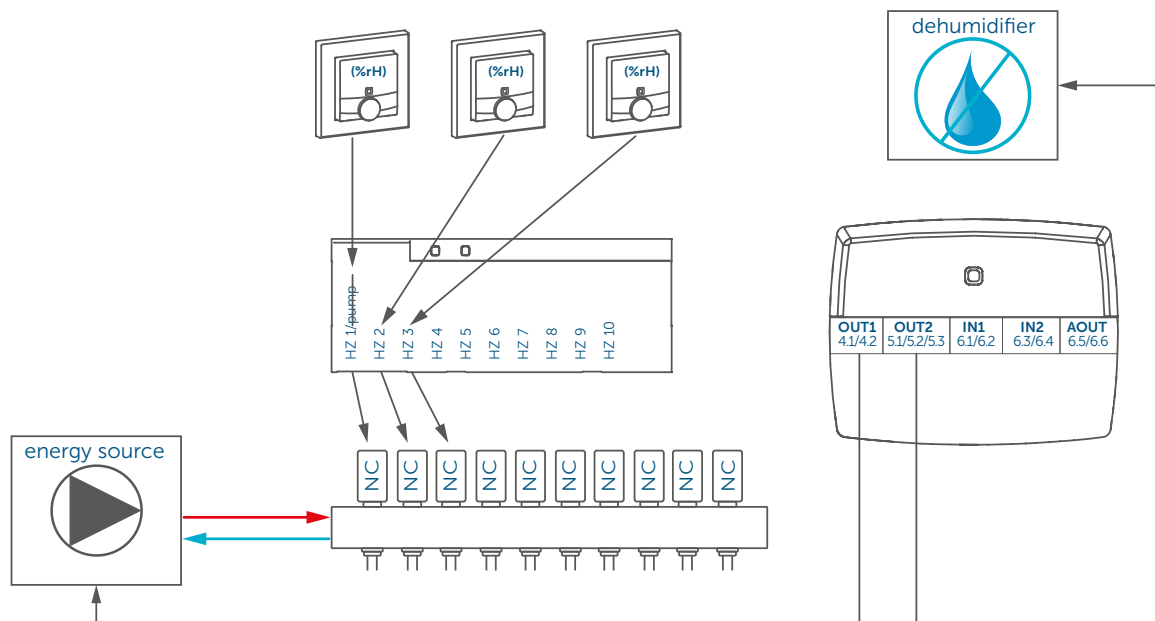

You can configure the devices for controlling the floor heating, the boiler and the dehumidifier as follows:

- Teach-in the floor heating actuator and assign every channel to a room.
- In the menu, tap "Device overview" and select the floor heating actuator.
- You will be directed to the device configuration in the next window.

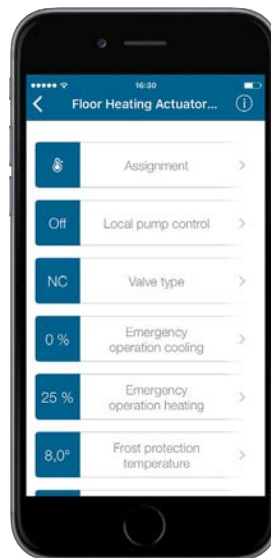

Figure 32: Screenshot configuration HmIP-FAL-xx

- Set the local pump control to “Off” and adjust the valve type to the variant used in your installation (NC or NO), if required.
- Teach-in the Multi IO Box.
- In the menu, tap “Device overview” and select the Multi IO Box.
- You will be directed to the device configuration in the next window.

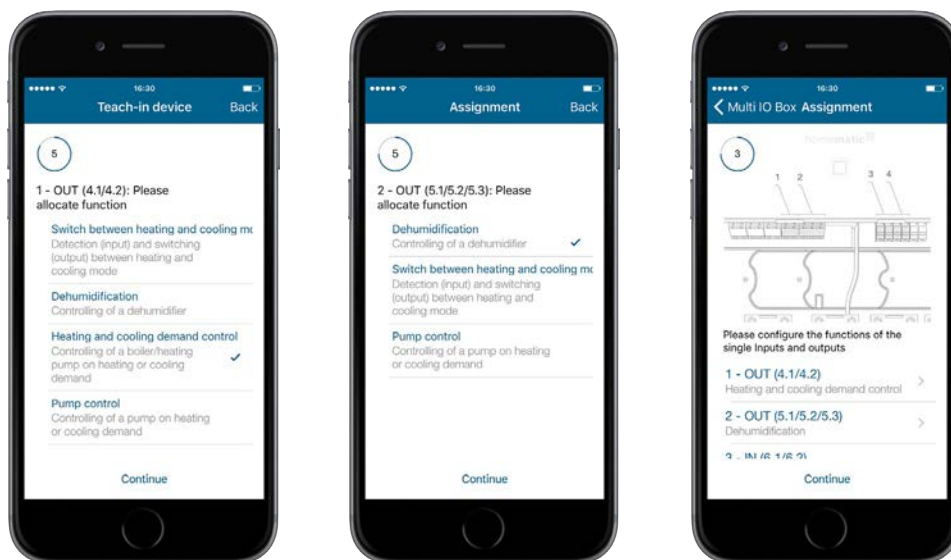

Figure 33: Screenshot HmIP-MIOB for controlling boilers/dehumidifiers

- In the menu item “Assignment” you can allocate output OUT1 to heating and cooling demand control. Afterwards, tap “Continue”.
- In the next window assign output OUT2 to the dehumidification control and tap “Continue”.
- Afterwards, a channel overview with corresponding functions is displayed.
- Additional settings can be adjusted by selecting the corresponding room.

7.6.4.4 Application example 4: Floor heating, heating pump, boiler and dehumidifier control

In this application example, the pump control is performed via the floor heating actuator. Thus, heating zone 1 controls only the pump.

The boiler is controlled via output OUT1 of the Multi IO Box. In this configuration, the boiler is switched on and off depending on the heat demand of the wall thermostats in the single rooms. A dehumidifier is controlled via the output OUT2 of the Multi IO Box. The current humidity is measured by the Homematic IP Wall Thermostat.

The inputs of the Multi IO Box are used for controlling the boiler.

The heating circuits 2-6 as well as 2-10 are connected via the Homematic IP Wall Thermostat. For controlling the floor heating, several floor heating actuators can be used.

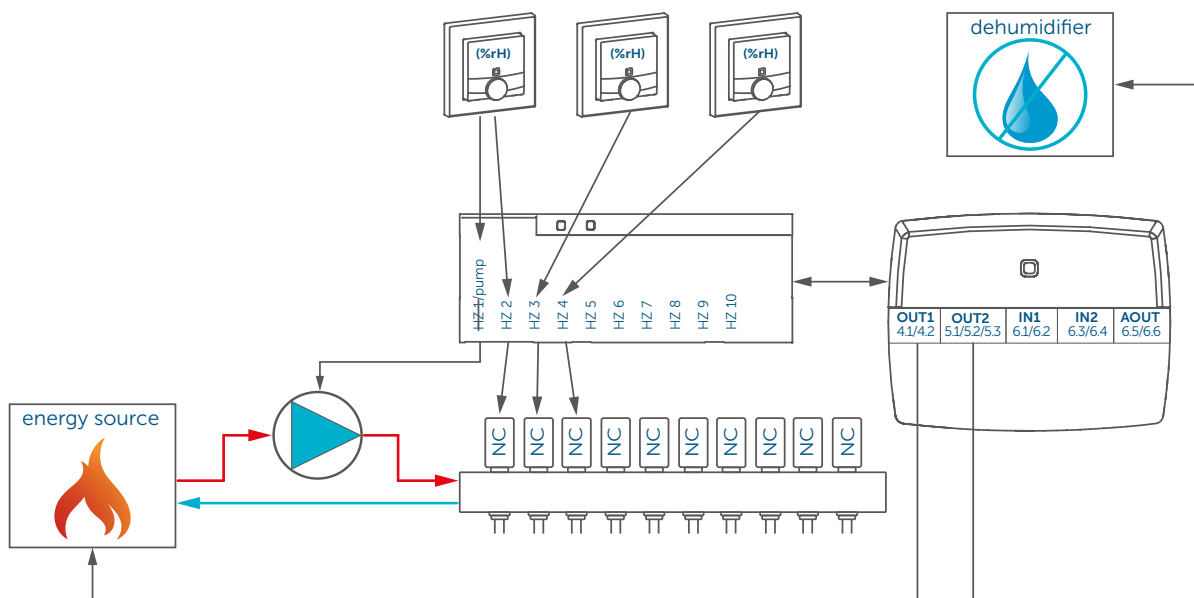

You can configure the devices for controlling the floor heating, heating pump, the boiler and the dehumidifier as follows:

- Teach-in the floor heating actuator and assign every channel to a room.
- In the menu, tap "Device overview" and select the floor heating actuator.
- You will be directed to the device configuration in the next window.

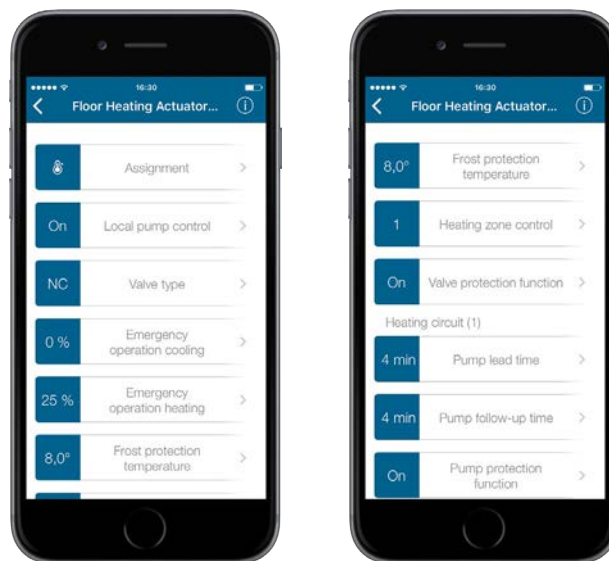

Figure 34: Screenshot configuration HmIP-FAL-xx for pump control

- Set the local pump control to “On” and adjust the valve type to the variant used in your installation (NC or NO), if required.
- Under “Heating circuit” you can configure the pump lead time and the pump follow-up time (see sec. „Pump lead time/pump follow-up time“ on page 90).
- Teach-in the Multi IO Box.
- In the menu, tap “Device overview” and select the Multi IO Box.
- You will be directed to the device configuration in the next window.

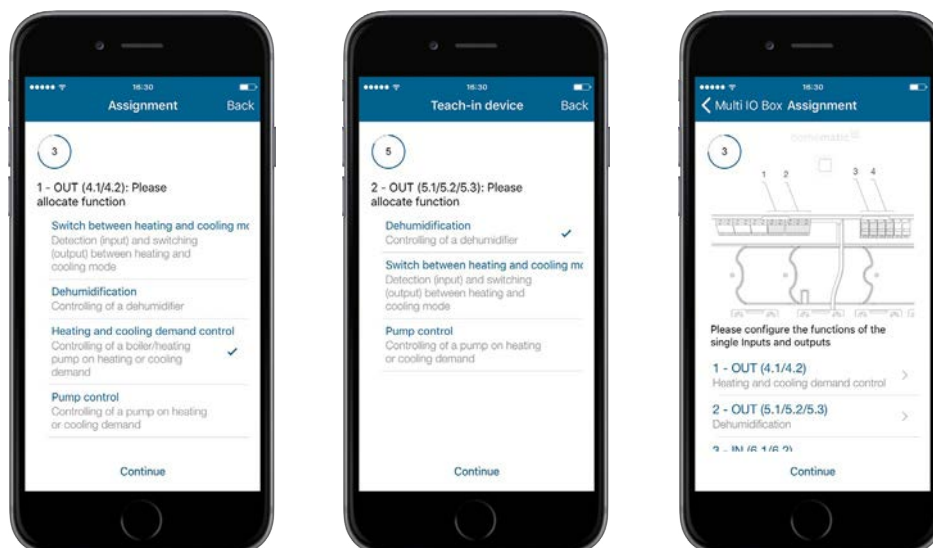

Figure 35: Screenshot configuration of HmIP-MIOB for controlling pumps/boilers/dehumidifiers

- In the menu item “Assignment” you can allocate output OUT1 to heating and cooling demand control. Afterwards, tap “Continue”.
- In the next window assign output OUT2 to the dehumidification control and tap “Continue”.
- Afterwards, a channel overview with corresponding functions is displayed.
- Additional settings can be adjusted by selecting the corresponding room.

7.6.4.5 Application example 5: Floor heating and heating pump control with switching from heating to cooling mode

You can use the floor heating actuator also in cooling mode and cool down your floor heating for reducing the room temperature e.g. in summer.



The cooling operation can be activated only for rooms where a floor heating system with cooling function is installed, for example a heating pump that offers this function.

The pump is controlled via the floor heating actuator. Thus, heating circuit 1 controls only the pump.

The boiler is controlled via output OUT1 of the Multi IO Box.

Switching between heating and cooling operation via the heating pump is controlled via the output OUT2 of the Multi IO Box. Switching between heating and cooling mode can be controlled only via the Homematic IP app.

The heating circuits 2-6 as well as 2-10 are connected via the Homematic IP Wall Thermostat. For controlling the floor heating, several floor heating actuators can be used.

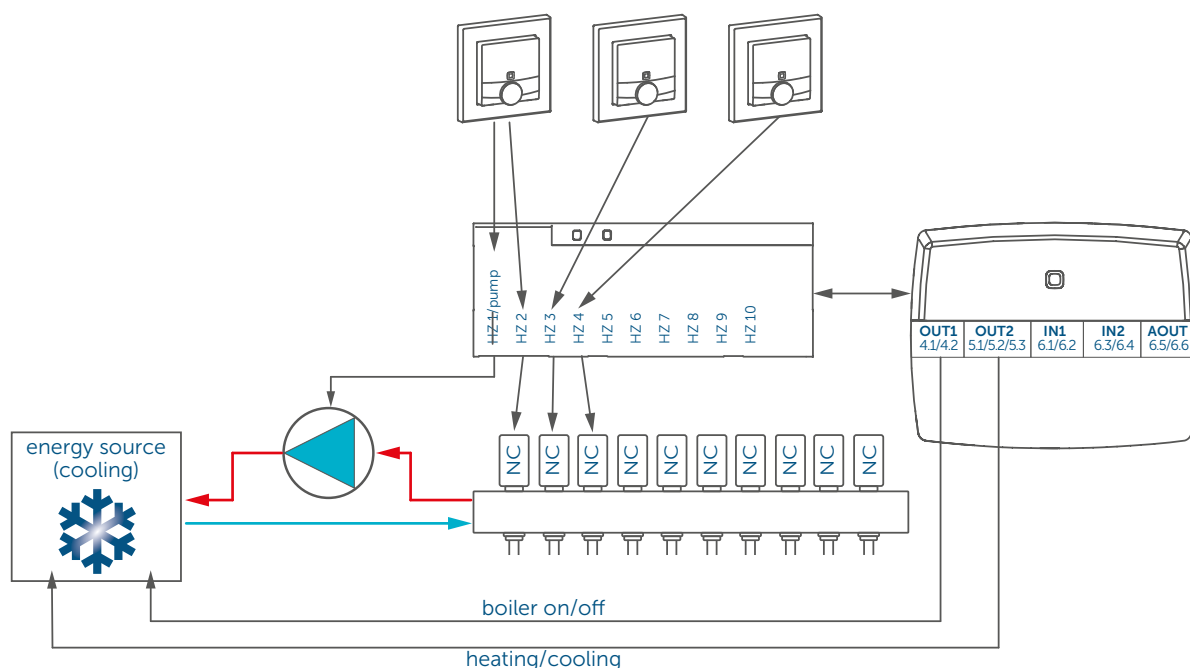

You can configure the devices for controlling the floor heating and pump with switching option between heating and cooling operation, as follows:

- Teach-in the floor heating actuator and assign every channel to a room.
- In the menu, tap "Device overview" and select the floor heating actuator.
- You will be directed to the device configuration in the next window.

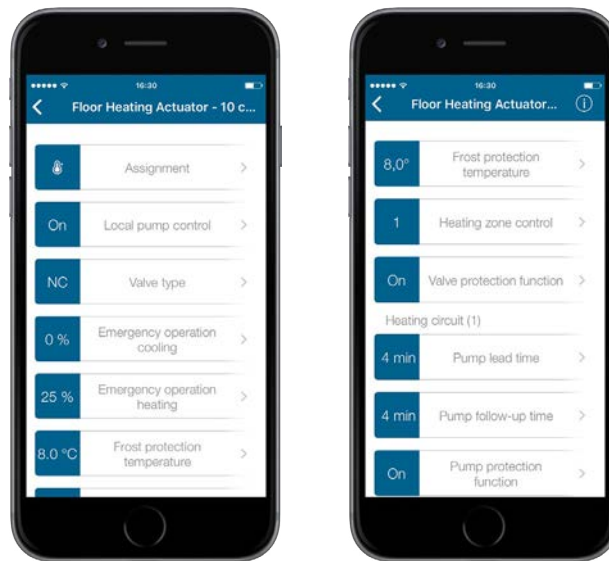

Figure 36: Screenshot configuration HmIP-FAL-xx for pump control

- Set the local pump control to “On” and adjust the valve type to the variant used in your installation (NC or NO), if required.
- Under “Heating circuit” you can configure the pump lead time and the pump follow-up time (see sec. „Pump lead time/pump follow-up time” on page 90).
- Teach-in the Multi IO Box.
- In the menu, tap “Device overview” and select the Multi IO Box.
- You will be directed to the device configuration in the next window.

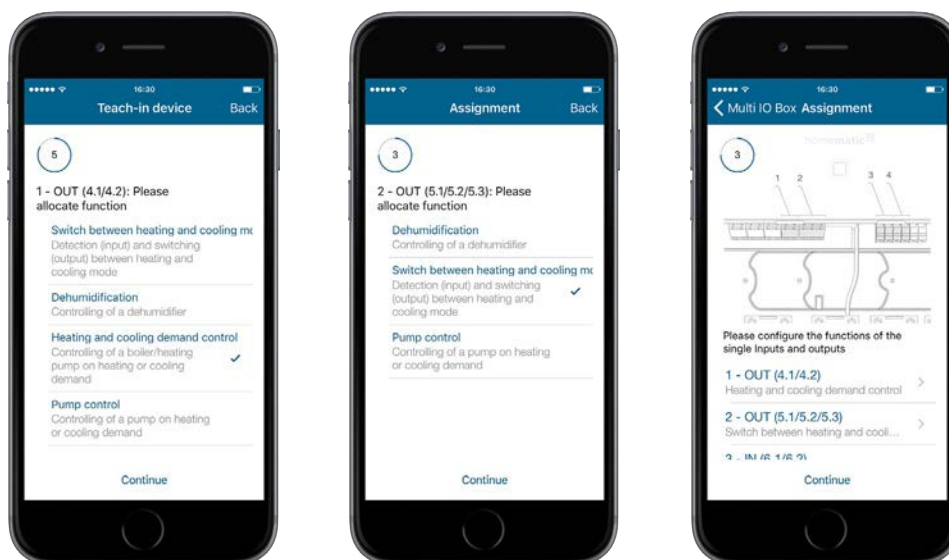

Figure 37: Screenshot configuration MIOB when using a pump

- In the menu item “Assignment” you can allocate output OUT1 to heating and cooling demand control. Afterwards, tap “Continue”.
- In the next window assign output OUT2 to “Switch between heating and cooling” and tap “Continue”.
- Afterwards, a channel overview with corresponding functions is displayed.
- Additional settings can be adjusted by selecting the corresponding room.

7.6.4.6 Cooling mode configuration

Via the menu you can adjust further settings for the cooling mode:

- In the main menu, tap “Climate control configuration”.

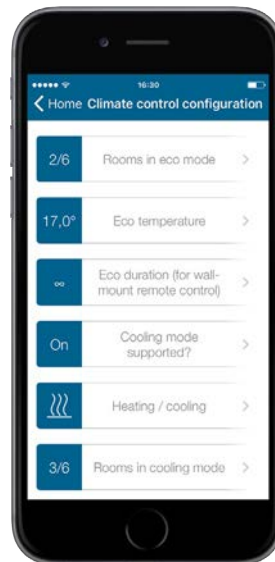

Figure 38: Screenshot cooling mode configuration

- Select via “Heating / cooling” between heating or cooling mode.
- Via the menu item “Rooms in cooling mode” you can select the rooms for which you want to activate the cooling mode.

Cooling profiles

If you have installed a Homematic IP Floor Heating Actuator and if your floor heating system supports a cooling function, you can use the menu item “Heating / cooling profiles” to select between three different cooling profiles in rooms where a floor heating is installed.

All cooling profiles available can be adjusted to your personal requirements in the same way like the heating profiles.

Adjustment of cooling profiles

You also have six options for adjusting the cooling profiles:

- Rename profiles
- Changing the base temperature
- Changing the predefined cooling phases
- Deleting and adding cooling phases
- Copying switching times to other weekdays
- Copying profiles to other profile positions (transferring complete cooling profiles to other rooms)

Selecting profiles

- Open the main menu (☰) Android or (☰) (iOS) and tap "Heating / cooling profiles".
- In the "Cooling profiles" menu, select the profile of the room you want to adjust by tapping on a predefined cooling profile under the relevant room. The profile is loaded and the profile overview is opened with the preset cooling profiles for each day of the week.



Figure 39: Screenshot cooling mode configuration

Rename profile

- Select in the "Cooling profiles" menu the profile of the room you want to adjust. Therefore, press and hold down the relevant profile.
- Tap on the pen icon in the menu bar, enter a new name and confirm your entry.
- In the profile overview select the profile that you want to rename. Therefore, swipe from right to left. Tap on "Rename" and enter a new name (iOS).
- After confirming the entry you will automatically get back into the "Heating profile" menu.



Changing the base temperature

- Tap on the top profile bar (Monday).
- Tap on "Base temperature" and adjust the base temperature via the control dial and tap on "Back" (Android) or "Done" (iOS).

Changing cooling phases

- Tap on the cooling phase you want to change. You can now change the corresponding fields beginning (left), setpoint temperature (middle) and end (right) of the selected cooling phase. For saving the changes of the profile tap three times on "Back" and afterwards on "Save" (Android) or "Done" (iOS).

Adding cooling phases

- Select in the profile overview of a room a day profile and tap on  (Android) or  (iOS). A new phase is opened for individual adjustment (refer to "Changing cooling phases").

Deleting cooling phases

- To delete a cooling phase, tap on  (Android) or swipe from right to left in the field of the selected cooling phase and tap on "Delete" (iOS). The cooling phase will be deleted.



Copying switching times to other weekdays and transferring of cooling profiles to other weekdays can be done as described in chapter "Adjusting the heating profile" on page 62.

7.6.4.7 Application example 6: Floor heating and heating pump control with switching between heating and cooling via external switch

When using a floor heating actuator with pump control and a Multi IO Box you can realise switching between heating and cooling via an externally connected switch. The pump is controlled via the floor heating actuator. Thus, heating circuit 1 controls only the pump.

The boiler is controlled via output OUT1 of the Multi IO Box. Switching between heating and cooling operation via the heating pump is controlled via the output OUT2 of the Multi IO Box. Switching between heating and cooling mode can be controlled only via input IN1 of the Multi IO Box. However, switching via app is deactivated.

The heating circuits 2-6 as well as 2-10 are connected via the Homematic IP Wall Thermostat. For controlling the floor heating, several floor heating actuators can be used.

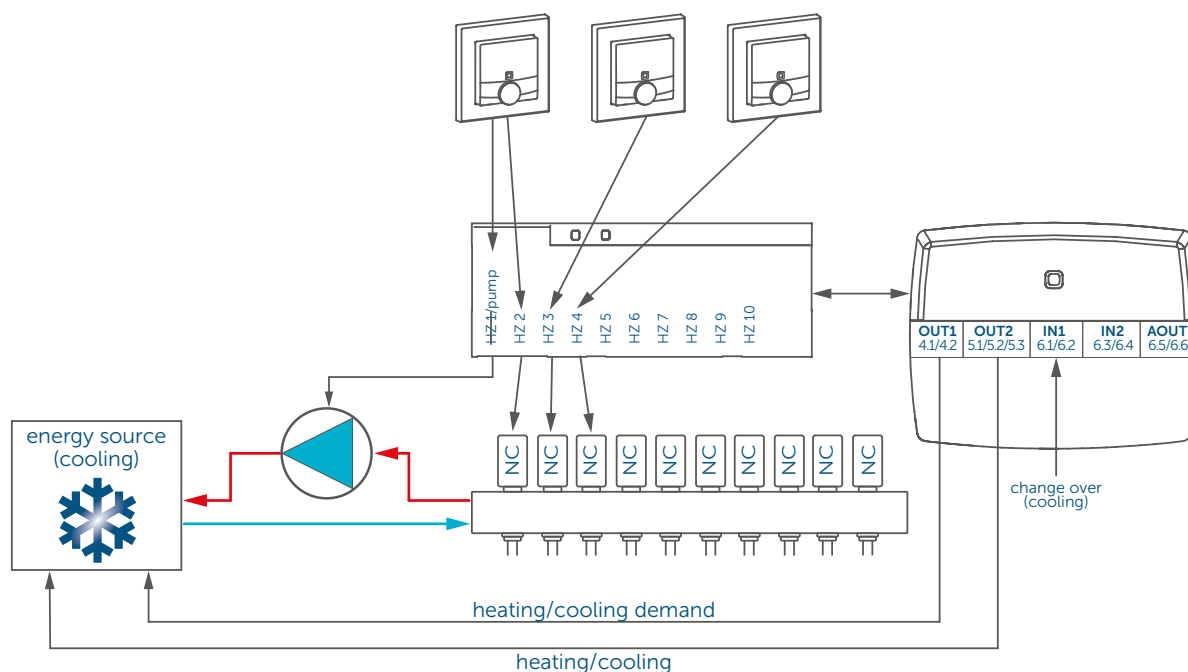

You can configure the devices for controlling the floor heating and pump with switching option between heating and cooling operation via external switch as follows:

- Teach-in the floor heating actuator and assign every channel to a room.
- In the menu, tap "Device overview" and select the floor heating actuator.
- You will be directed to the device configuration in the next window.

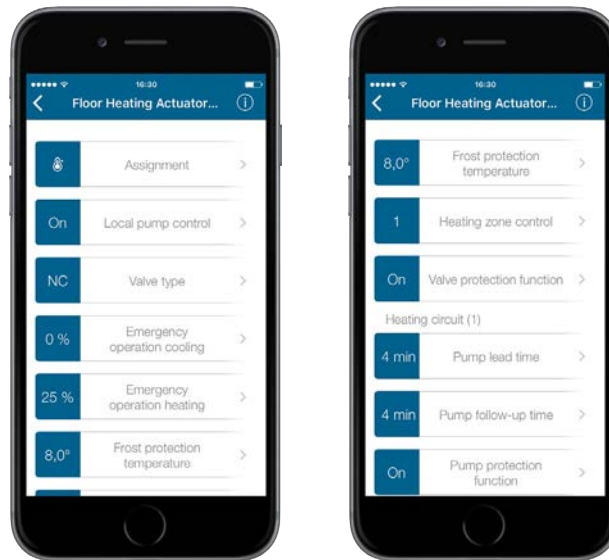

Figure 40: Screenshots configuration HmIP-FAL-xx

- Set the local pump control to “On” and adjust the valve type to the variant used in your installation (NC or NO).
- Under “Heating circuit” you can configure the pump lead time and the pump follow-up time (see sec. „Pump lead time/pump follow-up time” on page 90).
- Teach-in the Multi IO Box.
- In the menu, tap “Device overview” and select the Multi IO Box.
- You will be directed to the device configuration in the next window.

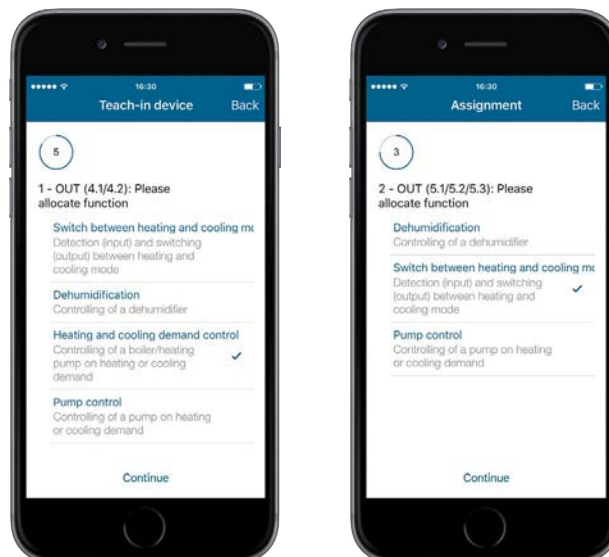

Figure 41: Screenshot configuration Multi IO Box for switching between heating and cooling operation via externally connected switch (1)

- In the menu item “Assignment” you can allocate output OUT1 to heating and cooling demand control. Afterwards, tap “Continue”.
- In the next window select for output OUT2 the option “Switch between heating and cooling mode” and tap “Continue”.

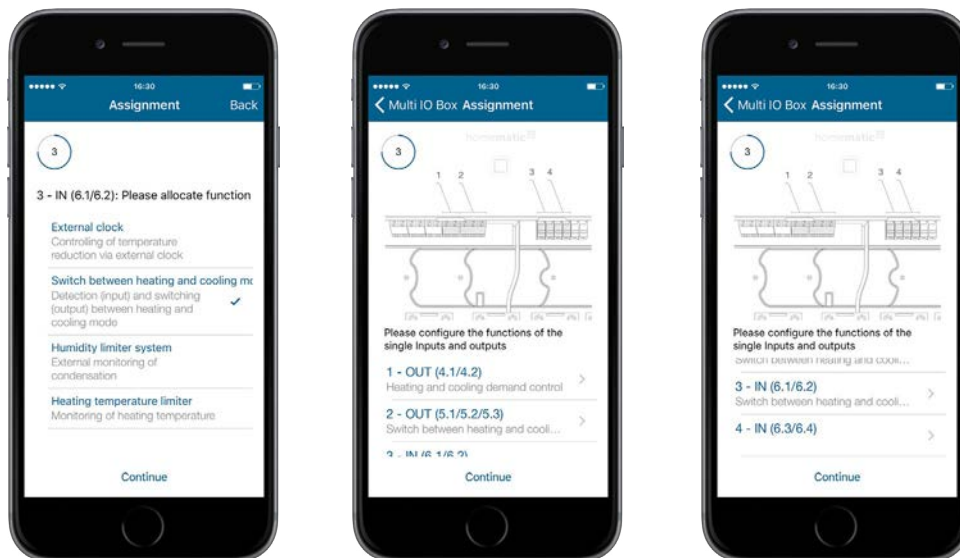

Figure 42: Screenshot configuration Multi IO Box for switching between heating and cooling operation via externally connected switch (2)

- Select for input IN3 the option "Switch between heating and cooling mode".
- Afterwards, a channel overview with corresponding functions is displayed.
- Additional settings can be adjusted by selecting the corresponding room.

7.6.4.8 Application example 7: Floor heating and heating pump control with switching between heating and cooling mode as well as humidity limit

When using a floor heating actuator with pump and Multi IO Box you can define a humidity limit. The cooling operation of the floor heating will be deactivated as soon as a humidity sensor that is connected to the Multi IO Box detects water or humidity. Thus, condensation water on the floor surface or the pipes of your heating system should be avoided.

The pump is controlled via the floor heating actuator. Thus, heating circuit 1 controls only the pump.

The heating pump is controlled via output OUT1 of the Multi IO Box.

The control input of the heating pump which takes care of switching between heating and cooling mode is connected to output OUT2 of the Multi IO Box. Input IN1 of the Multi IO Box controls the heating and cooling operation via a connected switch. An active humidity sensor with switching output is connected to input IN2.

The heating circuits 2-6 as well as 2-10 are connected via the Homematic IP Wall Thermostat. For controlling the floor heating, several floor heating actuators can be used.

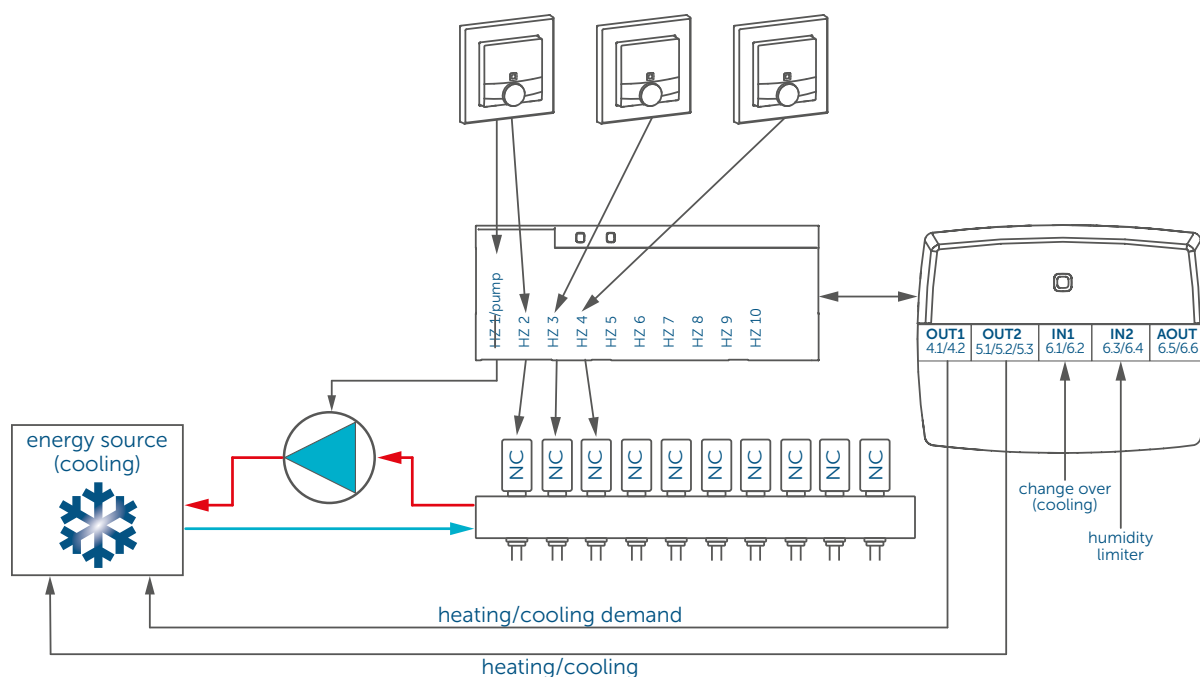

You can configure the devices for controlling the floor heating and heating pump with switching option between heating and cooling operation as well as humidity limit, as follows:

- Teach-in the floor heating actuator and assign every channel to a room.
- In the menu, tap "Device overview" and select the floor heating actuator.
- You will be directed to the device configuration in the next window.

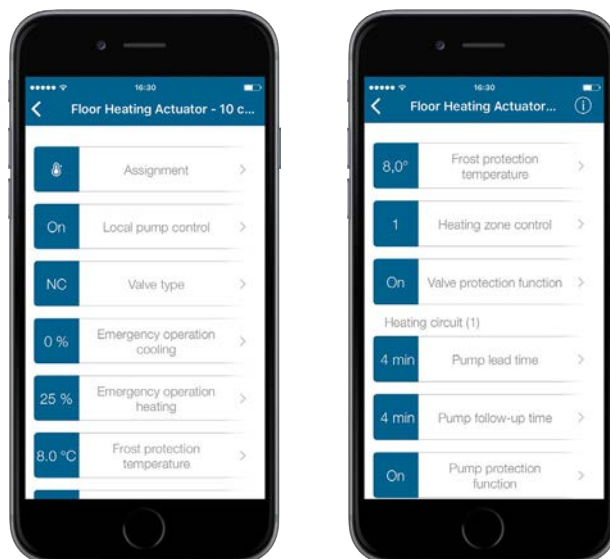

Figure 43: Screenshots configuration HmIP-FAL-xx

- Set the local pump control to “On” and adjust the valve type to the variant used in your installation (NC or NO).
- Under “Heating circuit” you can configure the pump lead time and the pump follow-up time (see sec. „Pump lead time/pump follow-up time” on page 90).
- Teach-in the Multi IO Box.
- In the menu, tap “Device overview” and select the Multi IO Box.
- You will be directed to the device configuration in the next window.

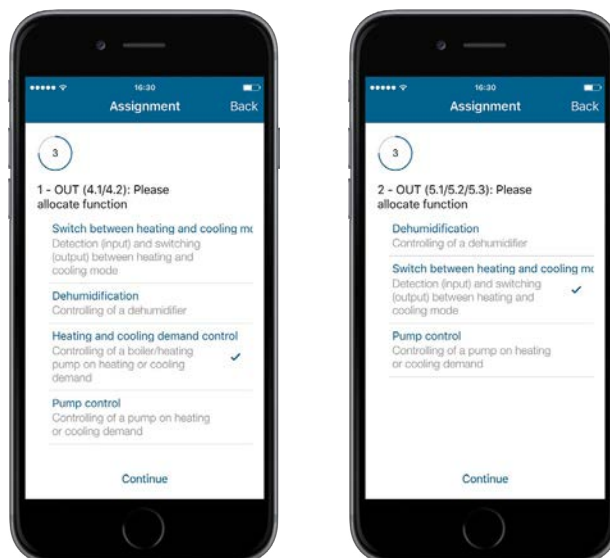

Figure 44: Screenshot configuration Multi IO Box for humidity limiter (1)

- In the menu item “Assignment” you can allocate output OUT1 to heating and cooling demand control. Afterwards, tap “Continue”.
- In the next window select for output OUT2 the option “Switch between heating and cooling mode” and tap “Continue”.

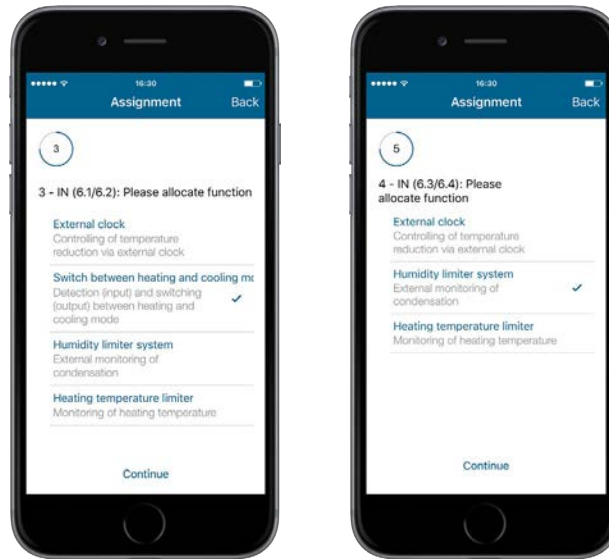

Figure 45: Screenshot configuration Multi IO Box for humidity limiter (2)

- Select for input IN3 the option “Switch between heating and cooling mode”.
- Allocate the option “Humidity limiter system” to input IN4.
- Afterwards, a channel overview with corresponding functions is displayed.

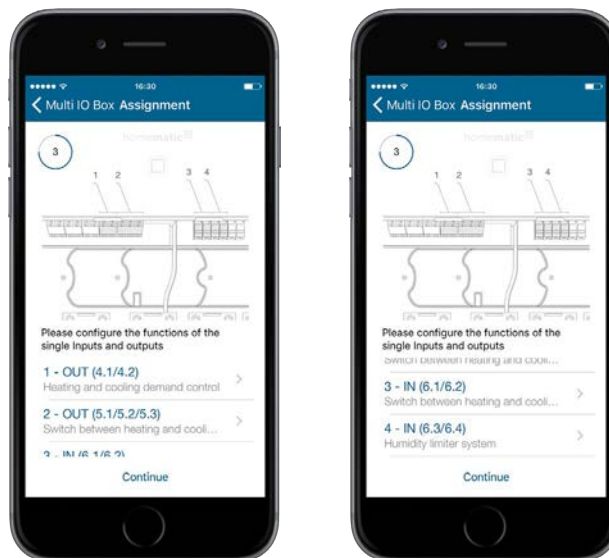

Figure 46: Screenshot channel overview configuration Multi IO Box for humidity limiter

- Additional settings can be adjusted by selecting the corresponding room.

7.6.4.9 Application example 8: Floor heating and heating pump control with temperature limit

When using a floor heating actuator with pump and Multi IO Box you can define a temperature limit. The pump is switched off and the floor heating actuator closes all valve drives if the temperature limiter detects a too high flow temperature.

The pump is controlled via the floor heating actuator. Thus, heating circuit 1 controls only the pump.

The boiler is controlled via output OUT1 of the Multi IO Box.

Input IN1 of the Multi IO Box controls the temperature limit. The heating circuits 2-6 as well as 2-10 are connected via the Homematic IP Wall Thermostat.

For controlling the floor heating, several floor heating actuators can be used.

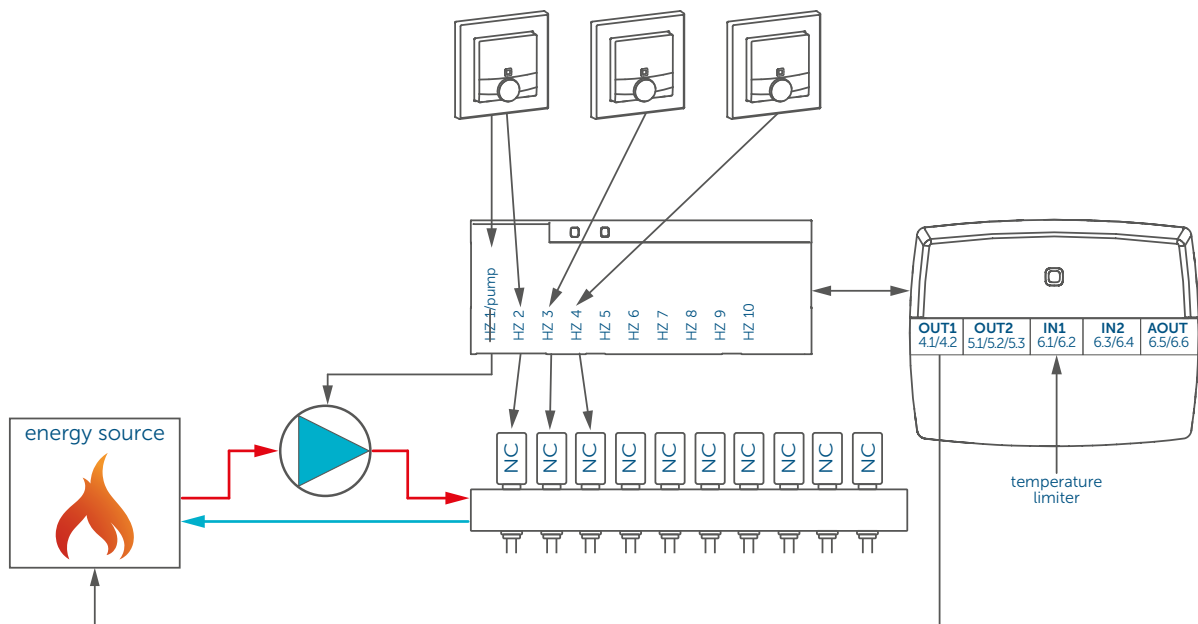

You can configure the devices for controlling the floor heating and the pump with temperature limit as follows:

- Teach-in the floor heating actuator and assign every channel to a room.
- In the menu, tap "Device overview" and select the floor heating actuator.
- You will be directed to the device configuration in the next window.

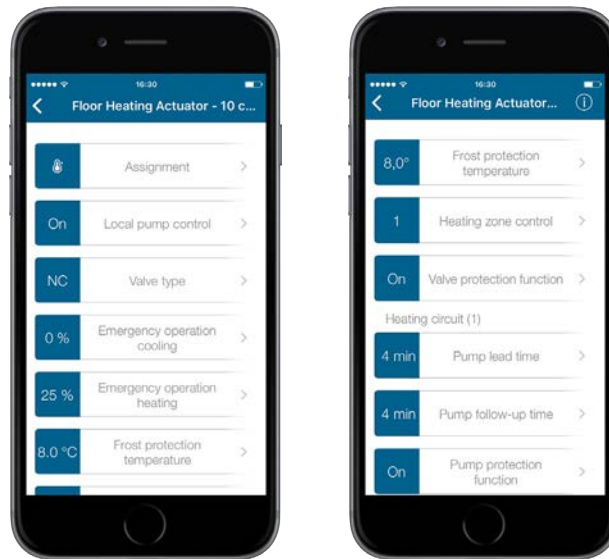

Figure 47: Screenshots configuration HmIP-FAL-xx

- Set the local pump control to “On” and adjust the valve type to the variant used in your installation (NC or NO).
- Under “Heating circuit” you can configure the pump lead time and the pump follow-up time (see sec. „Pump lead time/pump follow-up time” on page 90).
- Teach-in the Multi IO Box.
- In the menu, tap “Device overview” and select the Multi IO Box.
- You will be directed to the device configuration in the next window.

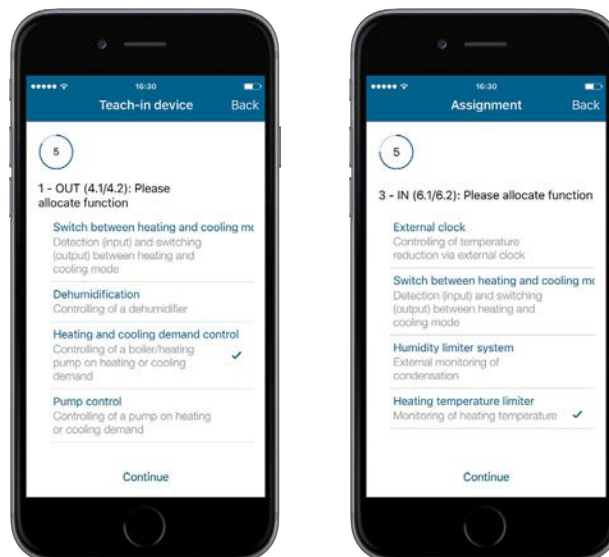

Figure 48: Screenshot configuration HmIP-MIOB for temperature limit

- In the menu item “Assignment” you can allocate output OUT1 to heating and cooling demand control. Afterwards, tap “Continue”.
- Select for input IN3 the option “Heating temperature limiter”.
- Afterwards, a channel overview with corresponding functions is displayed.

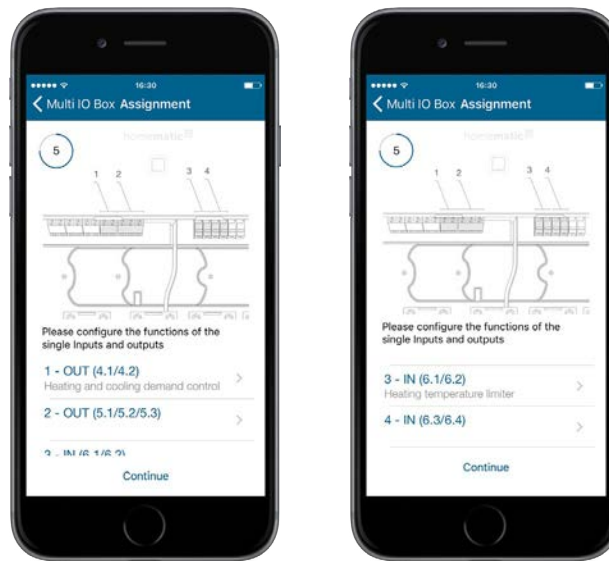

Figure 49: Screenshot channel overview HmIP-MIOB for temperature limit

- Additional settings can be adjusted by selecting the corresponding room.

7.6.4.10 Application example 9: Floor heating and heating pump control with external clock for temperature reduction mode

When using a floor heating actuator with pump and Multi IO Box you can define an external clock for automatic switching into temperature reduction mode.

The pump is controlled via the floor heating actuator. Thus, heating circuit 1 controls only the pump.

The boiler is controlled via output OUT1 of the Multi IO Box.

Input IN3 of the Multi IO Box controls the external clock. The heating circuits 2-6 as well as 2-10 are connected via the Homematic IP Wall Thermostat.

For controlling the floor heating, several floor heating actuators can be used.

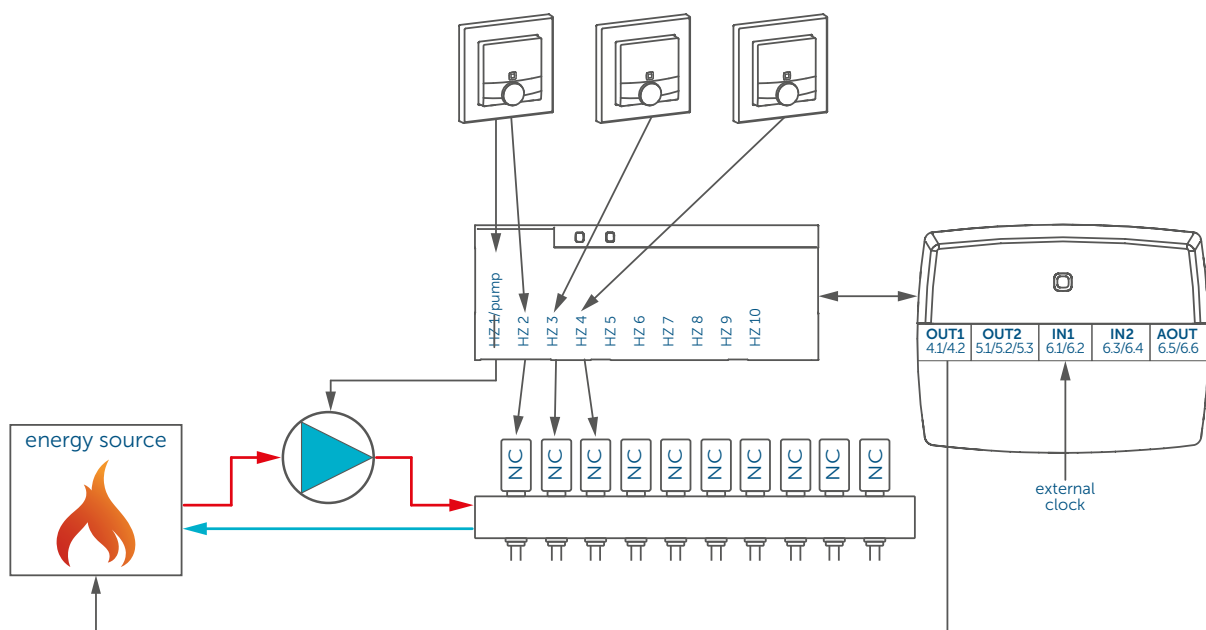

You can configure the devices for controlling the floor heating and pump with external clock for the temperature reduction mode as follows:

- Teach-in the floor heating actuator and assign every channel to a room.
- In the menu, tap "Device overview" and select the floor heating actuator.
- You will be directed to the device configuration in the next window.

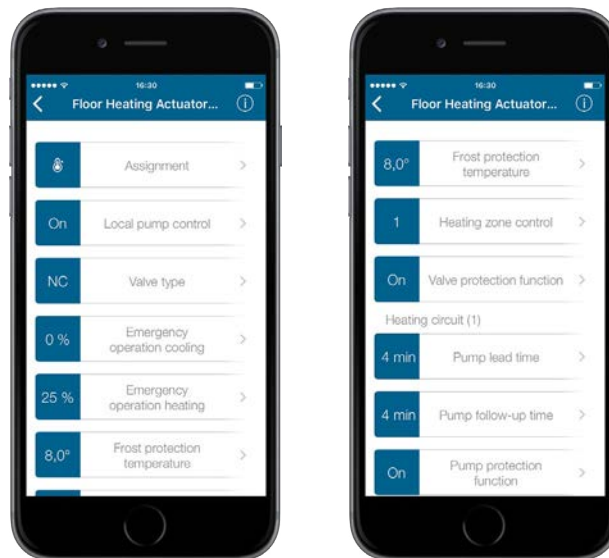

Figure 50: Screenshots configuration HmIP-FAL-xx

- Set the local pump control to “On” and adjust the valve type to the variant used in your installation (NC or NO).
- Under “Heating circuit” you can configure the pump lead time and the pump follow-up time (see sec. „Pump lead time/pump follow-up time” on page 90).
- Teach-in the Multi IO Box.
- In the menu, tap “Device overview” and select the Multi IO Box.
- You will be directed to the device configuration in the next window.

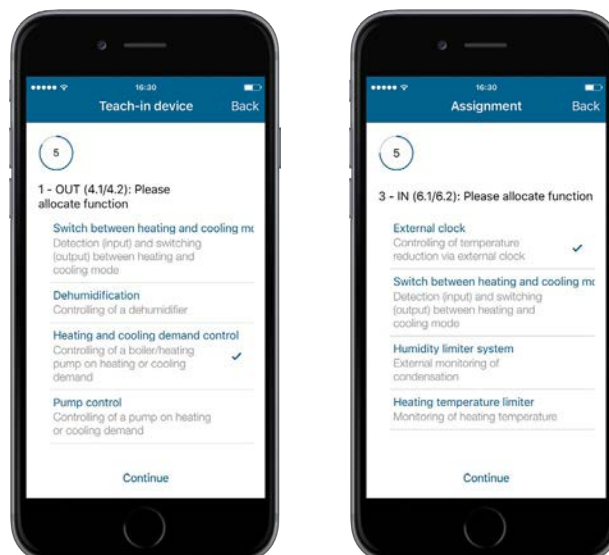

Figure 51: Screenshot configuration external clock (HmIP-MIOB)

- In the menu item “Assignment” you can allocate output OUT1 to heating and cooling demand control. Afterwards, tap “Continue”.
- Select for input IN3 the option “External clock”.
- Afterwards, a channel overview with corresponding functions is displayed.

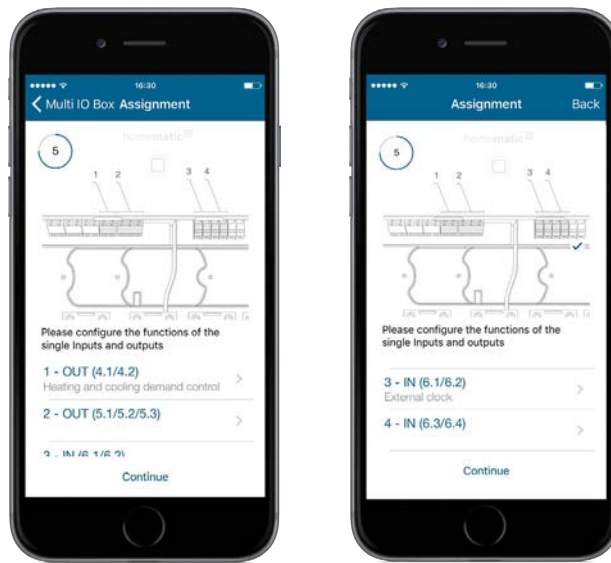

Figure 52: Screenshot channel overview external clock (HmIP-MIOB)

- Additional settings can be adjusted by selecting the corresponding room.

7.6.4.11 Application example 10: Floor heating and heating pump control with energy saving for cooling mode

When using a floor heating actuator with pump and Multi IO Box you can define an energy saving mode for operation in cooling mode. In this way, the temperature is e.g. increased in the night to save energy for the cooling temperature. Therefore, an external clock is required.

The pump is controlled via the floor heating actuator. Thus, heating circuit 1 controls only the pump.

The boiler is controlled via channel OUT1 of the Multi IO Box.

Via the app you can switch between operation in cooling or heating mode. Input IN3 of the Multi IO Box is controlled by the external clock. The heating circuits 2-6 as well as 2-10 are connected via the Homematic IP Wall Thermostat.

For controlling the floor heating, several floor heating actuators can be used.

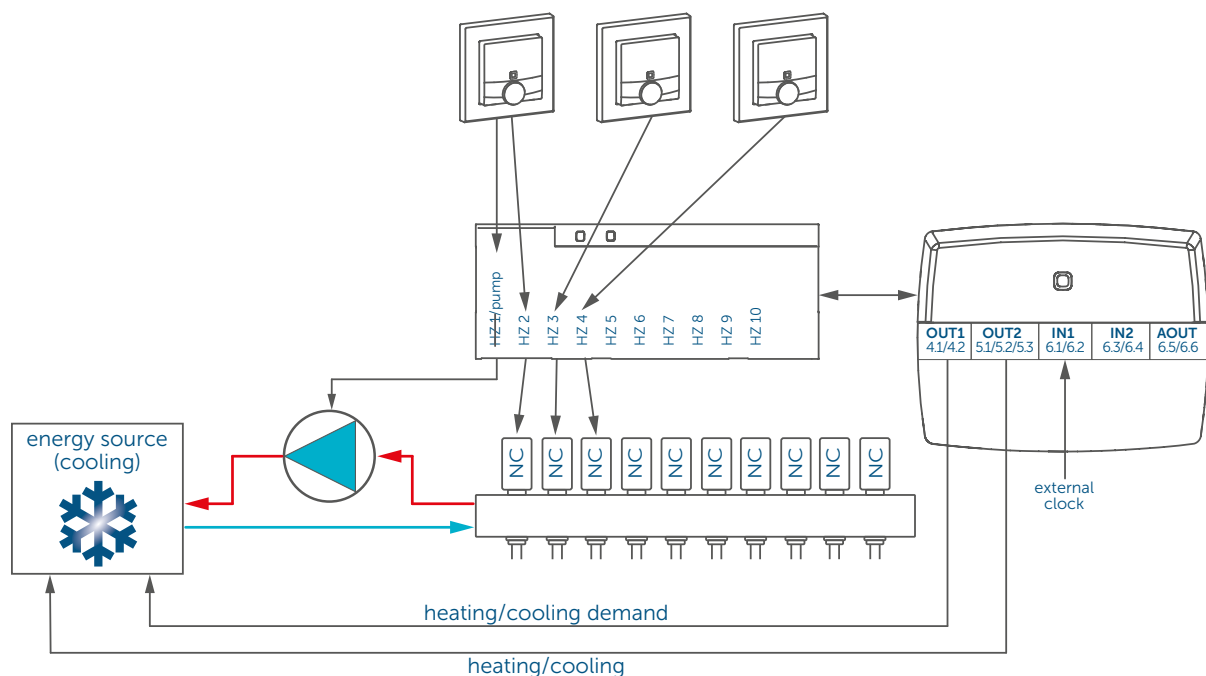

You can configure the devices for controlling the floor heating and pump with energy saving option for operation in cooling mode, as follows:

- Teach-in the floor heating actuator and assign every channel to a room.
- In the menu, tap "Device overview" and select the floor heating actuator.
- You will be directed to the device configuration in the next window.

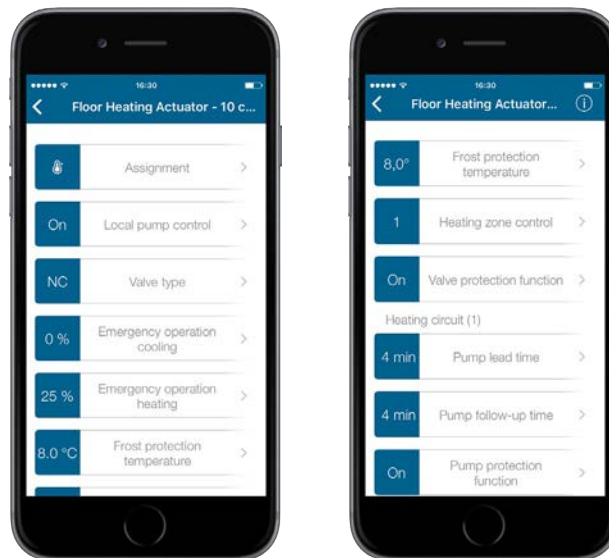

Figure 53: Screenshots configuration HmIP-FAL-xx

- Set the local pump control to “On” and adjust the valve type to the variant used in your installation (NC or NO).
- Under “Heating circuit” you can configure the pump lead time and the pump follow-up time (see sec. „Pump lead time/pump follow-up time” on page 90).
- Teach-in the Multi IO Box.
- In the menu, tap “Device overview” and select the Multi IO Box.
- You will be directed to the device configuration in the next window.

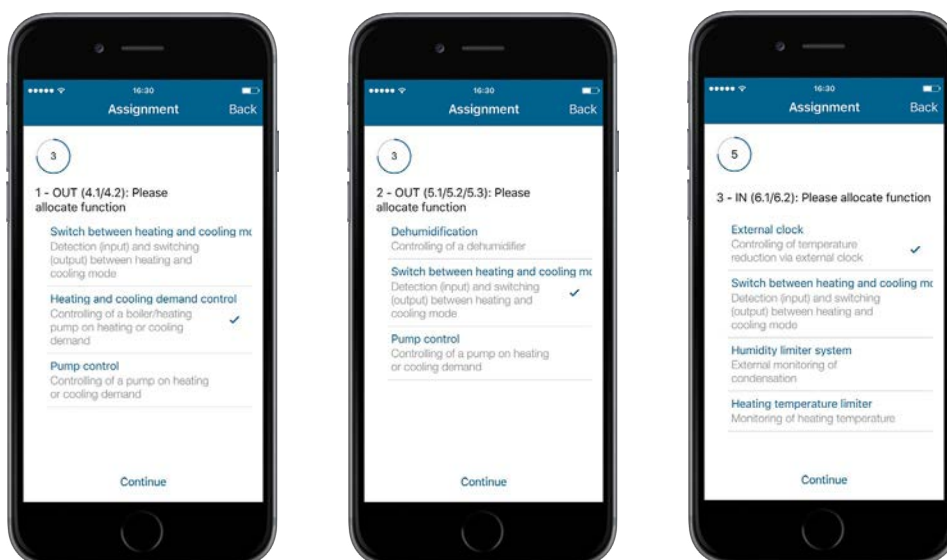

Figure 54: Screenshot configuration HmIP-MIOB for energy saving option in cooling mode

- In the menu item “Assignment” you can allocate output OUT1 to heating and cooling demand control. Afterwards, tap “Continue”.
- Select for output OUT2 the option “Switch between heating and cooling mode”.
- Select for input IN3 the option “External clock”.
- Afterwards, a channel overview with corresponding functions is displayed.

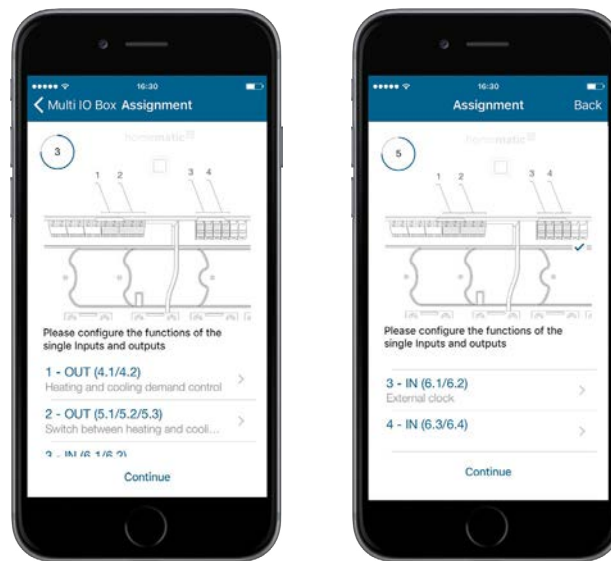

Figure 55: Screenshot channel overview HmIP-MIOB for energy saving option in cooling mode

- Additional settings can be adjusted by selecting the corresponding room.

8 SECURITY

No movement goes unnoticed with Homematic IP security components. Our security and alarm products increase the protection against break-ins and the sense of security in the own four walls. In alarm mode, users are informed whenever windows and doors are opened. Our motion detectors offer reliable monitoring in inside and outside areas while sirens and smoke alarms trigger an alarm in case of break-ins or fire. The Homematic IP Water Sensor immediately signals in case of detected humidity or water via an integrated siren or push-notification in the Homematic IP smartphone app. The alarm notifications in the app are differentiated into intrusion and hazard alarm. In addition, the device and room that have triggered the alarm are indicated in the alarm notifications. Thus, the source is localised immediately. Just a quick glance at the app is all it takes to see that everything is as it should be at home. You will no longer have to worry about windows and doors that are left open. And that even if you're thousands of miles away.

The alarm mode can be easily activated via app or Homematic IP Key Ring Remote Control. If the presence mode is activated, the system triggers an alarm as soon as windows or doors are opened unauthorised, for example. During activated "absence mode", also sensors for indoor areas like the motion detector are included. In case of alarm, an audio signal can be triggered via one or more Homematic IP Sirens or Smoke Alarms and a push notification is send to all connected smartphones. The alarm protocol provides an overview of all activities in your home at any time.

With the extended security solution, a default alarming mode is available, that ensures secure protection also in case of inactive cloud connection: The Homematic IP Alarm Siren triggers an alarm also if there is not active Internet connection or the Homematic IP Access Point is not available, e.g. due to power failure. You will find further information about the extended security solution in the section "8.4 Configuration of the security solution".

8.1 The benefits

Over the last years, the number of break-ins has continuously increased. According to the German insurance industry the number of domestic burglaries has increased by 35 % between 2010 and 2015. Only in 2014, the registered household insurance holders in Germany have registered more than 150,000 break-ins⁴.

Considering this development for many people there is an increasing need to protect their homes and to make it at least more difficult for unwanted visitors to enter the house.

The Homematic IP security solution contributes to this need for increased security. Either used as independent security solution or as extension of an already existing Homematic IP system, it offers effective and secure protection and alarm functions for your home. However, the single components are fully compatible with already existing products and can be installed as easy as the Homematic IP climate control solution.

In terms of security, the devices of the Homematic IP security solution certainly meet the standards just like all other Homematic IP products.

Most fire victims are injured at night in the own four walls. Especially dangerous is not only the fire, but also smoke. The Homematic IP Smoke Alarm offers reliable protection if dangerous smoke gas caused by incipient fires is detected and reliably triggers an alarm via a loud siren.

⁴ Gesamtverband der deutschen Versicherungswirtschaft e.V. (German insurance association), "More security for private living space", 05/2016.

8.2 Installation planning

The Homematic IP security solution is installed and operated just as easy as the Homematic IP climate control solution. With its reliable protection and alarm functions it does increase the security - for you, your family and your belongings. In times of increasing mobility it is a good feeling to be able to monitor the home also while being out and about. It contributes to the increasing need for security of many people and helps to protect against unpleasant surprises.

The following provides useful information about planning your Homematic IP security solution.

I have already installed a Homematic IP climate control solution. Is it possible to integrate the security solution into my system?

From the very beginning, Homematic IP has been designed as modular system. The Homematic IP security solution fits seamlessly into an already existing system – including the set-up and control of all existing and new components via the smartphone app. Another advantage: some devices of the climate control solution, like the window and door contacts for example, take over additional security functions after integration into the security solution and thus offer additional benefits.

I am living in a rented flat. Can I use the Homematic IP security solution as well?

All Homematic IP components can be removed without damage at any time and can, for example, easily be installed in a new flat. However, the Homematic IP security solution is appropriate for the protection of rented flats just as for own houses.

What has to be considered for the installation position of Homematic IP security devices?

If possible, place your security components in that way, that they are not directly recognisable from the outside. A motion detector for monitoring rooms should be positioned so that a burglar is reliably recognised on his way through the house/flat, e.g. in the area of an entrance or terrace door.

Which Homematic IP devices can I use to install a security solution in my flat/my house?

The following will indicate an overview of devices that can be used for the security solution. Apart from the Access Point, the number and type of devices is variable.

- **Homematic IP Access Point**

Since the Access Point transfers the configuration data and operating commands to the single Homematic IP components, it should be placed as centrally as possible to ensure ideal radio connection to the devices.



Note: For further information about the ideal installation position of your Homematic IP components please refer to section "3.3 Wireless range".

- **Homematic IP Motion Detector with Brightness Sensor – indoor/ Homematic IP Presence Sensor – indoor**

Motion detectors and presence sensors should be mounted in areas that have to be passed after unauthorised passage through a flat or house. Especially consider the detection angle of the motion detector. Also in rooms where valuable objects are stored, monitoring by motion detectors is recommended.

- **Homematic IP Motion Detector for 55mm frames – indoor**

The battery operated Homematic IP Motion Detector enables easy integration into existing switch ranges for 55mm frames of leading manufacturers. Besides detection of motion, the device offers comfortable control, e.g. of connected light sources via two integrated push-buttons.



In the device overview, you can activate or deactivate the option “Permanently ready to receive” in the settings of the motion detector. If the option is deactivated, the device is only listening in certain cycles and thus saves energy when operating the device with batteries. Please note that this function is only useful if the device is used for light control via the push-buttons or for the detection of motion. When using the device in a Homematic IP security solution, supply voltage must be connected via the Homematic IP Power Supply Unit for brand switches (HmIP-BPS).

- **Homematic IP Motion Detector with Brightness Sensor – outdoor**

The motion detector for outdoor areas offers additional security for your house and garden. The lens of the device can be rotated through 360° and also tilted in the wall mount. This means that the detection range can be set to virtually any angle to the wall and the floor. For example, use the motion detector to switch lights or to detect motion in outdoor areas.

- **Homematic IP Window / Door Contact – optical / Homematic IP Window / Door Contact – invisible installation**

Window and door contacts reliably inform users, if a window or door is open or closed and thus protect the building envelope. Therefore, you should equip all windows and doors concerned, especially entrance and terrace doors, with a window and door contact.

The window and door contact for invisible installation into frames of plastic windows or doors is especially inconspicuous and not visible from the outside. Therefore, it is especially appropriate to secure windows and doors.

- **Homematic IP Window Handle Sensor**

The window handle sensor recognises whether a window is open, closed or tilted via the position of the window handle. This offers additional protection against break-ins as you are immediately informed as soon as a window is opened in case if the alarm mode is activated. Therefore, secure all windows that are concerned with a window handle sensor. The device is small and inconspicuous and fits to all standard window handles. In addition you can adjust the colour of your window handle sensor to your window handle using the supplied silver or white covers.

- **Homematic IP Alarm Siren – indoor and outdoor**

In case of alarm, the alarm siren takes care of reliable loud acoustic and optical signalling. Install the alarm siren – indoor into your house in that way that the alarm sound can be perceived by all inhabitants in case of alarm.

The alarm siren for outdoor use offers sustainable energy supply thanks to the integrated solar cell. It can be mounted flexibly and easily on the wall outside the reach of a burglar.

- **Homematic IP Smoke Alarm with Q label**

The smoke alarm is intended for use in a network with other wireless smoke alarms of the same type. The device can be connected to a maximum number of 40 smoke alarm devices, using the Homematic IP Access Point. This provides an extra level of safety: In the event of fire the wireless smoke alarm simultaneously sends an alarm to all devices that are located within wireless range. Thus, you can react early enough to a fire that may still be some distance away, perhaps in another room on a different floor of the building.

Minimum protection

For minimum protection, sleeping areas such as children's rooms or bedroom, as well as corridors must be controlled by wireless smoke alarms. In buildings where ceilings are extended over multiple floors at least one wireless smoke alarms has to be installed on the upper floor.

Recommended protection

It is always recommended to install several wireless smoke detectors in your house or flat and if possible in every room. This is the only way to ensure that a timely and, as a result, an effective warning can be given in the early stages of a fire.



For further important information about the installation of the smoke alarm, please refer to the user manual of the device.

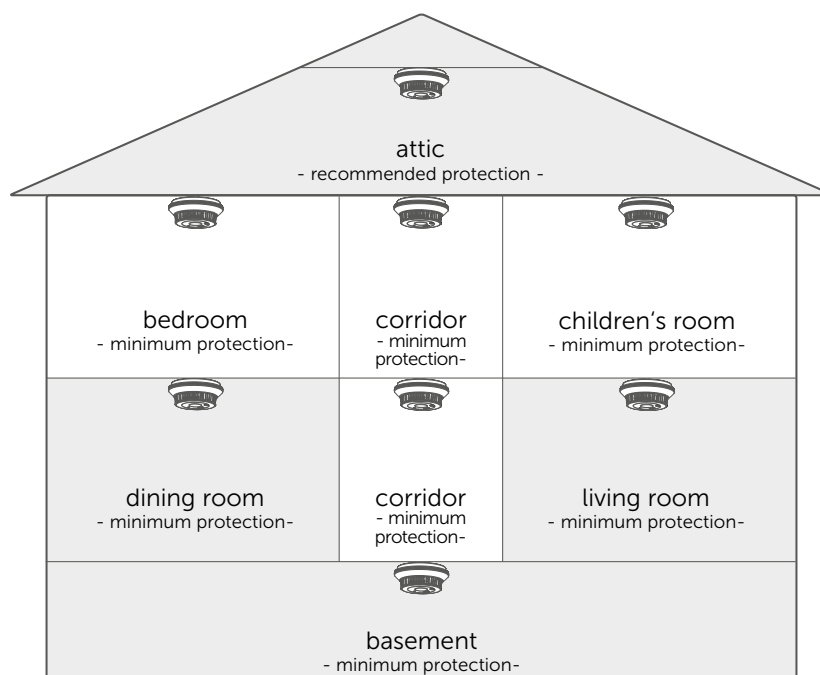

Figure 56: Installation instructions Homematic IP Smoke Alarm with Q label

- **Homematic IP Key Ring Remote Control – alarm**
Besides the app, the key ring remote control offers a very comfortable possibility to activate or deactivate alarm functions or to control light functions within the radio range of the device. The number of remote controls used depends on the number of persons in your household.
- **Homematic IP Switch and Meter (with indoor siren or light)**
If you use a Homematic IP Pluggable Switch or a Homematic IP Pluggable Switch and Meter in connection with an indoor siren within your security solution, position the device as centrally in your house as possible so that all inhabitants in your home are alarmed and the deterrence effect is optimised. For application in connection with light groups, the installation site depends on the selected group function.
- **Homematic IP Wall-mount Remote Control**
The wall-mount remote control switches the panic light. It should be mounted so that it can be reached and confirmed immediately in case of alarm (e.g. beside the bed).
- **Homematic IP Water Sensor**
The water sensor reliably detects humidity as well as water from 1.5 mm height. The device detects humidity or water e.g. in the bathroom or in cellars) via the measuring probes at the bottom. The water sensor offers two different types of measuring probes. The first is used to detect humidity, even if no stagnant water has formed yet, while the second is able to detect water from 1.5 mm height. Via the integrated siren, a loud alarm signal is emitted immediately and a push-notification with an alarm message is sent to the smartphones of the inhabitants. A tilt sensor detects and reports any unwanted motion or manipulation. Alarm configuration and the triggering behaviour of the water sensor can easily be adjusted to your personal preferences using the free app. For further information about configuring the water sensor, please refer to the next section.

8.2.1 Configuration of the Homematic IP Water Sensor (HmIP-SWD)

For the configuration of the water sensor, please proceed as follows:

Select the water sensor in the device list of the app. You can select between different configuration possibilities.

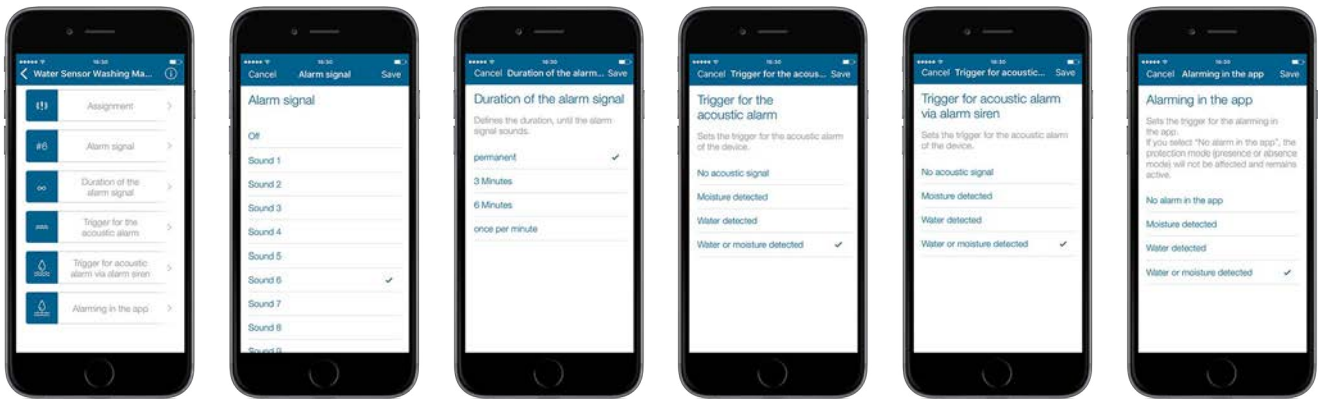

Figure 57: Configuration of the Homematic IP Water Sensor (HmIP-SWD)

Assignment

You have already assigned your water sensor to a room during teach-in. If you would like to assign the water sensor to another room, you can change the room allocation here.

Alarm signal

Via this menu item you can select between nine different signal tones for acoustic signalling via the Homematic IP Water Sensor or deactivate the acoustic signalling.

In the menu, select the desired signal sound by selecting the radio button (Android) or tapping the sound (iOS). You can select "Off" to deactivate the acoustic signal.

Duration of the alarm signal

Use this menu item to define the duration of the alarm signal.

In the menu, select the desired duration (permanent, 3 minutes, 6 minutes or once per minute) via the radio buttons (Android) or tap on the desired option (iOS).

Trigger for the acoustic alarm

Here, you can define the trigger for the acoustic alarm of the device.

- No acoustic signal: When selecting this option, no acoustic signal is triggered.
- Humidity detected: An acoustic signal is triggered only if humidity is detected.
- Water detected: An acoustic signal is triggered only if water of at least 1.5 mm is detected.
- Water or humidity detected: An acoustic signal is triggered, if water or humidity are detected.

Trigger for acoustic alarm via alarm siren



This menu item is only displayed when using a Homematic IP Alarm Siren (HmIP-ASIR).

In addition to alarming via the built-in siren, the Homematic IP Alarm Siren (HmIP-ASIR) can be used to signal the water alarm at another location in the home. Here, you can define the trigger for the acoustic alarm of the additional alarm siren.

- No acoustic signal: When selecting this option, no acoustic signal is triggered via the alarm siren.
- Humidity detected: An additional acoustic signal is triggered only if humidity is detected.

- Water detected: An additional acoustic signal is triggered only if water of at least 1.5 mm is detected.
- Water or humidity detected: An additional acoustic signal is triggered, if water or humidity are detected.

Alarming in the app

In this menu item you can deactivate the alarm in the app or define under what condition an alarm in the app is triggered.

In the menu, select the desired option via the radio buttons (Android) or tapping the desired option (iOS).



Even with deactivated alarming in the app, the states can still be used in the automation function.



If you deactivate alarming in the app for the Homematic IP Water Sensor, the protection mode of the security solution (presence or absence mode) is not affected and remains activated.

8.3 Alarm messages in the app

The Homematic IP app offers reliable alarming by sending push notifications to the smart phone, even when on the move. In alarm situations, the message is directly sent to the user's smartphone.



Please note that you smartphone requires active Internet connection to receive the push notifications.

A distinction is made between an intrusion alarm and hazard alarm.

Intrusion alarms are triggered, for example, by activated motion or window sensors. Therefore, the protection mode (absence or presence mode) have to be activated. If a motion is detected after activation, in the event of a break-in for example, the user immediately receives a message on the smartphone.

Hazard alarms are detected at all times and transmitted to the user. Activation of the protection mode is therefore not necessary. Hazard alarms include detected water, for example, that is detected by the water sensor or smoke detected by a smoke alarm.

You can individually define, which notifications you want to receive.

- Open the main menu and tap on Settings, Notifications, Notifications.
- Select between the notification options for
 - Battery state low
 - Smartphone added
 - Maintenance tasks
 - Protection mode changes
 - Alarm and activation error
 - Humidity warning

The alarm sound for receiving a push-notification in alarm cases on your smartphone can be configured individually.

- Open the main menu and tap on Settings, Notifications, Alarm sound. You can select between different sounds.

Alarm Siren – indoor

In this menu item you can configure the settings for your indoor siren(s).

- Operating time of siren: You can adjust the operating time of the siren in this menu item. 3 minutes are set as default, alternatively you can select between 4, 5 and 6 minutes.
 - Alarm signal (acoustic): Via this menu item you can select between nine different signal tones for acoustic signalling via the Homematic IP Alarm Siren or deactivate the acoustic signalling.
 - In the menu, select the desired signal sound by selecting the radio button (Android) or tapping the sound (iOS). You can select "Off" to deactivate the acoustic signal.
 - Confirm your selecting by tapping "Confirm" (Android) or "Done" (iOS).
- The app automatically returns back to the menu item "Alarm configuration".



If you tap "Test alarm" after selecting a sound, the alarm siren plays the selected signal sound for function check.

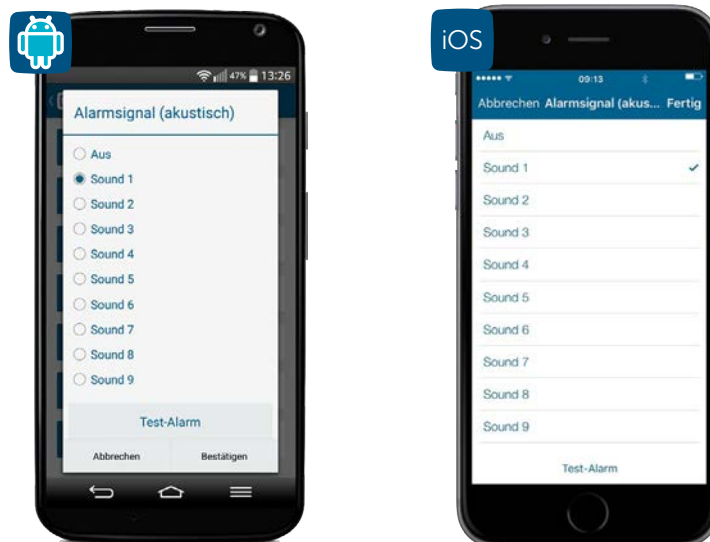

Figure 58: Screenshot alarm signal (acoustic)

- Alarm signal (optical): You can select between four light signal variants or deactivate the optical alarm signal.
 - In the menu, select the desired light signal by selecting the radio button (Android) or tapping on the light signal (iOS). You can select "Off" to deactivate the optical signal.

- Confirm your selecting by tapping "Confirm" (Android) or "Done" (iOS).

The app automatically returns back to the menu item "Alarm configuration".



If you tap "Test alarm" after selecting a light signal, the alarm siren shows the selected light signal for function check.

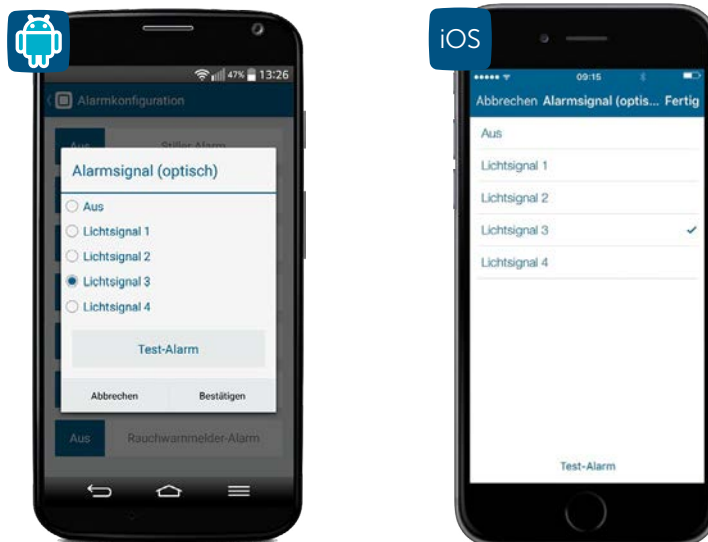

Figure 59: Screenshot alarm signal (acoustic)

- Acoustic confirmation of siren: After activating this option, the siren confirms the change of the protection mode with a short tone sequence.

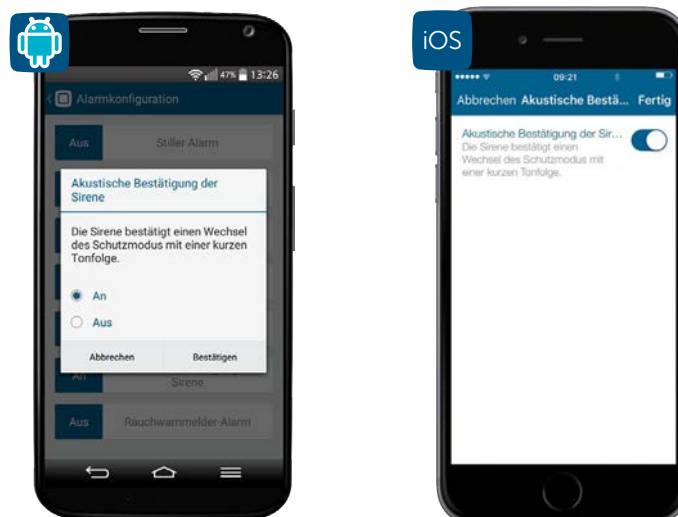

Figure 60: Screenshot acoustic confirmation of siren

Alarm Siren – outdoor

The alarm sirens for indoor and outdoor applications can be configured separately. In this menu item you can configure the settings for your outdoor siren(s). The same menu items as for the alarm siren – indoor are available.

8.4 Activate alarm mode

As soon as you have installed the security solution via the app, the security icon appears on the homescreen of the app (🔒). Via this icon, you can quickly select the alarm mode.



Figure 61: Home screen

- Tap the security icon.
- Select the device alarm mode by tapping the corresponding icon.
- Confirm your selection with "OK".

Protection deactivated: The alarm mode of the system is deactivated. All security functions are deactivated.

Presence mode: The security functions of all devices that you have selected for the presence mode are activated.

Absence mode: The security functions of all security solution components are activated.

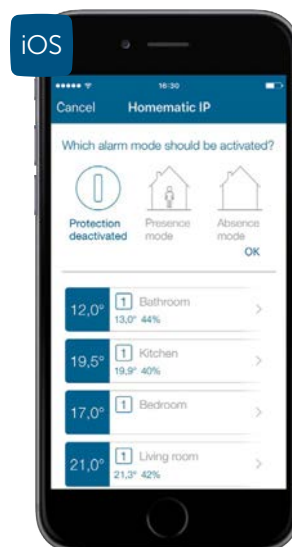

Figure 62: Screenshot security mode settings

As soon as an alarm mode is triggered during activated presence mode or absence mode, e.g. in case of unauthorised opening of windows and doors or detected motion via the motion detector, you are immediately informed via push-notification on your smartphone. The alarm message indicates which device has triggered an alarm at what time.

The messages are differentiated into intrusion and hazard alarm. Intrusion alarms are only being triggered, if the protection mode has been activated previously. Hazard alarms are detected at every time. They include damages caused by water and detected by a water sensor or smoke that is detected by a smoke alarm device, for example.



Figure 63: Screenshot security mode settings

- Tap the system button “Cancel” to close the alarm message and to leave the previously selected protection mode activated.
- Tap “Confirm” to close the alarm message and to deactivate the protection mode.



If you have integrated an alarm siren into your system, an additional alarm sound is triggered via the siren in accordance with the alarm message on your smartphone. You can also use the Homematic IP Smoke Alarm as a siren.



As soon as smoke is detected, the smoke alarm triggers a loud signal sound and immediately transmits an alarm message to your smartphone. Smoke detection is permanently activated, independent from the protection mode of the system.



If an alarm message is already confirmed by another user when several smartphones are used in the system, a grey alarm message is displayed on all other smartphones.

8.4.1 Security information in the menu item “Security”

Via the menu item “Security” you can check the security status of a selected room also while you are away from home. You are informed about the type of protection mode (protection deactivated, presence mode, absence mode) and the active or inactive sensors, depending on the pre-defined protection mode.

- In the homescreen of the app, select the room for verifying the security status.
- Swipe the semicircle in the middle right side of the screen to the left and tap "Security".



Figure 64: Screenshot selection of "Security"

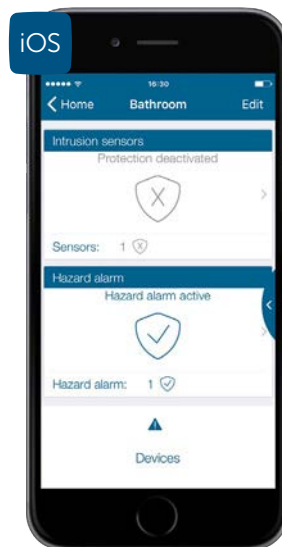

Figure 65: Screenshot security information room

You can swipe the semicircle again to the left and tap on the menu item "Climate control" or "Light" to change to the desired menu at any time.

8.5 Configuration of the security solution

After setting-up the Access Point (see sec. „5.1.3 Set up your Access Point“ on page 27) and teaching-in the security components (see sec. „5.3 Teaching-in devices“ on page 32) please select in the next step in which application you want to use the connected device. By selecting the option “Security”, these devices are available for the security functions.

Teach-in the device in the main menu via “Teaching-in devices”. After registration to the Access Point, the assignment options of the device are requested.

- If possible, select by tapping on one or more icons in which **solution** you want to use the device and tap “Continue”.



For devices that are used for the security solution only, e.g. the alarm siren, this step is skipped as the device is assigned automatically.

- If the option is displayed, select the room in which you want to use the device.
- Enter the device name and tap “Continue”. You can optionally change the device name generated by the system or add a new name.
- After teaching-in has been successful, tap “Done”.

Subsequently, the configuration of your security components is performed in the main menu via “Security”, using the menu items **Alarm configuration**, **Light groups** and **Absence mode** (see below).

Several devices can be used for different applications at the same time. If previously selected, the Homematic IP Window / Door Contact can for example take over heating control as well as security functions. If required, you can change or delete the allocation via the device overview afterwards.



For a pluggable switch or a pluggable switch and meter that you want to use for light control within the security solution, select the “Light” solution.

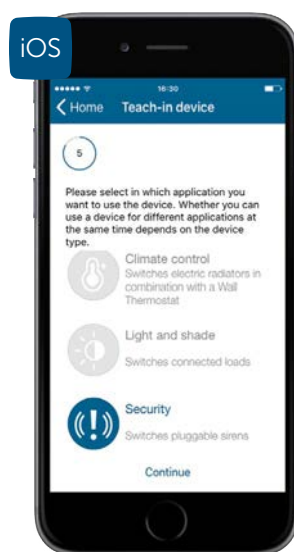

Figure 66: Screenshot selecting the assignment to a solution

8.5.1 Alarm protocol

The alarm protocol offers detailed information in chronological order about any activity or event in the system. So you always have in sight what has happened in your home in terms of security. Tap one of the listed events to receive more detailed information like date or time as well as information about the triggering device or the alarm message.

- Tap in the app homescreen on the main menu icon (☰) (Android) or (☰) (iOS) and there on "Security" and "Alarm protocol".
- The alarm protocol with a list of security relevant events is opened.
- You can scroll down to get an overview of previous days. Up to a maximum number of 100 events can be displayed.



You can delete the alarm protocol at any time, if required. If you have assigned a PIN for the app, enter the PIN for deleting. After deleting, the alarm protocol will be continued.

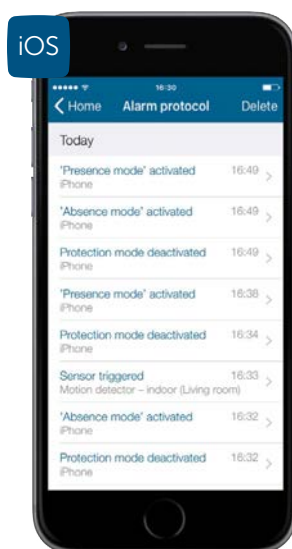

Figure 67: Screenshot alarm protocol

8.5.2 Alarm configuration

This menu offers an overview about the current configuration of the alarm functions in your security solution as well as individual, demand-based configuration possibilities.

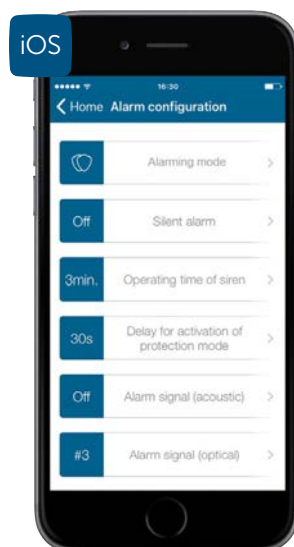

Figure 68: Screenshot alarm configuration

Alarming mode

In the menu item 'Alarming mode', two options are available:

- Alarming pro:** This mode is set as default. The alarm mode - presence as well as absence mode - can be activated only via the app or the key ring remote control – alarm (HmIP-KRCA) if all sensors are in normal mode (e.g. window closed, housing cover mounted, etc.) and within the wireless range. If the battery status of one of the devices is low - this will be displayed in the homescreen of the app - the batteries of the corresponding devices have to be replaced. Furthermore, the Homematic IP Access Point has to be online while activating the alarm. If an alarm siren (HmIP-ASIR) is used, it will be triggered even if there is no connection to the Homematic IP cloud (with a delay of 10 seconds). Furthermore, the Homematic IP Alarm Siren can transfer the alarm message also to the Homematic IP Smoke Alarm, if the smoke alarm is configured accordingly via the alarm configuration. You will receive a push notification with an alarm message on your smartphone, as soon as the cloud connection will be established again.

Via the Homematic IP Key Ring Remote Control - alarm (HmIP-KRCA) you can also deactivate the alarm mode, if there is no connection to the Access Point.

Therefore, the security solutions still works correctly also during inactive Internet connection, e.g. if the router software will be updated by the provider.

- Alarming basic:** The alarm mode can be activated via the app or key ring remote control – alarm (HmIP-KRCA) if single sensors cannot be activated (e.g. if a window is open, the device cover is not mounted or a device is not within the wireless range, etc.). If an alarm siren (HmIP-ASIR) is used, it will be triggered only if an active connection to the Homematic IP cloud is established.



The alarm mode "Presence/Absence" can be activated using "Alarming pro" only via the app, if all security-related Homematic IP devices are updated with the current firmware version: Information about the device updates can be found in the menu item 'Device updates'.

Silent alarm

- If the silent alarm is activated, the indoor siren and the alarm light will not be triggered. In case of alarm, the system does only send a push-notification to the app.

Operating time of siren

- You can adjust the operating time of the siren in this menu item. 3 minutes are set as default, alternatively you can select between 4, 5 and 6 minutes.

Delay for activation of protection mode

- In this menu item you can define a delay for activating the protection mode of the system. A delay does especially make sense for houses that are left via an area that is monitored by a motion detector or where a window / door contact is mounted on the front door.

Smoke alarm notification

- Via this menu item, you can include all Homematic IP Smoke Alarms installed. In case of intrusion detected, all smoke alarms trigger an acoustic signal.



The integration of smoke alarms may shorten the battery life of your smoke alarm.

Alarm sirens – indoor

This menu item is used to configure the settings of your indoor siren(s).

-

Alarm signal (acoustic)

- Via this menu item you can select between nine different signal sounds for acoustic signalling via the Homematic IP Alarm Siren or deactivate the acoustic signalling.
 - In the menu, select the desired signal sound by tapping on the radio button (Android) or tapping on the sound (iOS). You can select "Off" to deactivate the acoustic signal.
 - Confirm by tapping "Confirm" (Android) or "Done" (iOS).

The app automatically returns back to the menu item "Alarm configuration".



If you tap "Test alarm" after selecting a sound, the alarm siren plays the selected signal sound for function check.

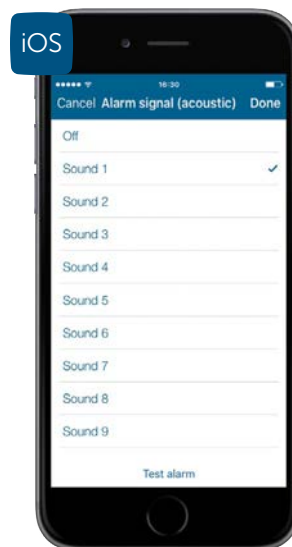

Figure 69: Screenshot alarm signal (acoustic)

Alarm signal (optical)

- You can select between four light signal variants or deactivate the optical alarm signal.
 - In the menu, define the desired light signal by selecting the radio button (Android) or tapping on the light signal (iOS). You can select "Off" to deactivate the optical signal.
 - Confirm your by tapping "Confirm" (Android) or "Done" (iOS).

The app automatically returns back to the menu item "Alarm configuration".



If you tap "Test alarm" after selecting a light signal, the alarm siren shows the selected light signal for function check.



Figure 70: Screenshot alarm signal (acoustic)

8.5.3 Light configuration

In this menu, you can configure the light functions of your security solution.

8.5.3.1 Alarm light

In this menu item you can define, if and which light source is switched on in case of alarm.

- Tap on "Alarm light" in the "Light groups" menu.
- Select the devices that are listed by rooms for switching on connected light sources in case of alarm.
- Tap on "OK" (Android) or "Done" (iOS).

You can activate one or more devices for this function.



Figure 71: Screenshot alarm light

8.5.3.2 Panic light

Here you can select the light source(s) that are switched after pressing the wall-mount remote control.

- In the "Light groups" menu, tap on "Panic light".
- Select the devices that are listed by rooms for switching on connected light sources after pressing the wall-mount remote control.
- Tap on "OK" (Android) or "Done" (iOS).

You can activate one or more devices for this function.



Figure 72: Screenshot panic light

8.5.3.3 Coming home light

The coming home light provides light for dark areas in the entrance and is switched via the light button of the key ring remote control.

- In the "Light groups" menu, tap "Coming home light".
- Select the devices that are listed by rooms for switching on connected light sources after pressing the light button of the key ring remote control.
- Tap "Done".

You can activate one or more devices for this function. The coming home light is switched off by a long button press of the key ring remote control light button.



Figure 73: Screenshot coming home light

8.5.4 Presence mode

In this menu item you can select the Homematic IP security components that are used for the presence mode.

- In the "Security" menu, tap on "Presence mode".
- Select the devices listed by rooms that you want to use for presence mode and tap on the back icon (Android) or "Done" (iOS).

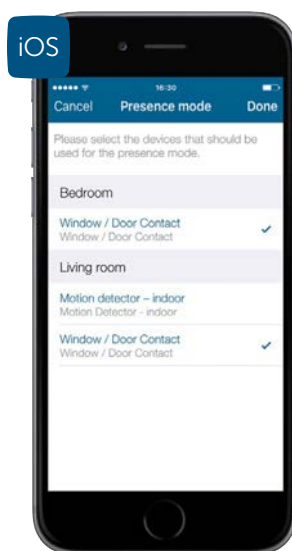





Figure 74: Screenshot presence mode

8.6 Integration of Smartfrog cameras into the Homematic IP system

Benefit from reliable camera surveillance and additional security in your own four walls: By combining Homematic IP with Smartfrog's cloud-based camera solution, you can integrate one or more Smartfrog IP cameras into your smart home system. In this way, you can always keep an eye on your home, even when you are out and about. The Smartfrog app immediately informs you if anything is moving in your house.

-  In order to integrate the Smartfrog camera into your Homematic IP system, it is necessary to create a Smartfrog account and download the Smartfrog app.
-  For a successful installation of the camera you need your WLAN key.
-  You can integrate up to 10 cameras into your smart home system.

Proceed as follows to put the Smartfrog camera into operation:

- Connect your smartphone to the WLAN network (if you haven't already) that you want to use for your webcam.
- Download the free Smartfrog app for iOS or Android to your smartphone and open

the Smartfrog app.

- Tap on "Register now" and create a Smartfrog account. Therefore, only an email address is necessary.
- Assign a password and finish the registration.
- In the menu of the smartphone app, select "Connect Smartfrog cam".
- Connect the camera to the power supply using the supplied AC adapter and wait until the LED starts to flash green.
- Enter the WLAN key to connect the camera to your WLAN.
- Enter a camera name to finish installation for your Smartfrog camera.
- Configure the camera using your smartphone app and position the camera at your desired location.

You can then integrate the Smartfrog camera into your Homematic IP smart home system:

- Open the Homematic IP app.
- Tap in the app homescreen on the main menu symbol (☰) (Android) or (☰) (iOS) and select in the main menu "Camera".
- Tap the + sign at the bottom right of the screen to integrate the camera. You will be redirected to the Smartfrog login page.

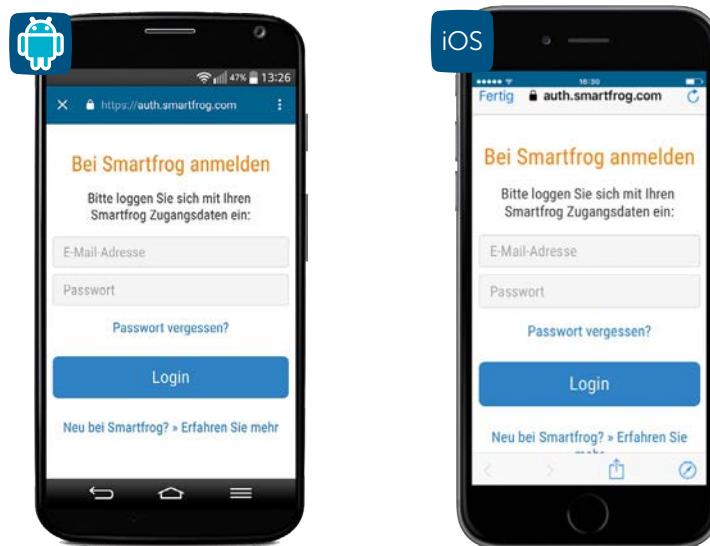

Figure 75: Login with the Smartfrog login data

- Log in with your Smartfrog account and agree to the authorization between Homematic IP and Smartfrog.
- A preview image of your camera will appear in the following window.
- Tap on the preview image to be able to see the live images. Here you can adjust the volume of the camera as well as the display size on your smartphone.
- Tap the "Refresh"-icon at the top right of the screen to update the preview image.
- To log out your Smartfrog camera from the Homematic IP app, tap the menu icon and "Logout".

To integrate additional cameras into your system, proceed again as described above.

If an alarm is triggered in your Homematic IP system while the absence mode is activated, you can access the camera directly via the alarm message and have your home immediately in view.

9 SHUTTER CONTROL

Shutters and blinds darken rooms, create a sense of privacy and increase the security. With our shutter and blind actuators, the window coverings can be set up in just a few single steps using the Homematic IP app. Afterwards, they are raised or lowered automatically.

The actuators are controlled comfortably via individual week profiles, also depending on the sunrise and sunset. Furthermore, active shutters and blinds make the home look inhabited even if you are not at home. In addition to the anti-burglary effect of shutters, our solution thus actively increases the security. Another advantage: In case of increased room temperatures due to strong sunlight, shutters or blinds are automatically lowered to prevent the room from heating up.

The Homematic IP Blind Actuators also allow the exact adjustment of the slats position of exterior and interior blinds. If necessary, also awnings can be integrated into the smart home using our products. The automatic storm protection avoids damages of shutters, interior blinds and awnings during unfavourable weather conditions and thus raises or lowers the window coverings. To protect windows and doors it is also possible to move down blinds and shutters automatically.

9.1 The benefits

Shutters, blinds and awnings fulfil a wide range of important functions. **Shutters** protect your windows from the effects of wind and weather. They provide reliable visual protection and thus offer increased privacy. Furthermore, they avoid thermal loss during winter as well as excessive heating of rooms in case of strong sunlight. Thanks to the additional noise reduction, the shutters also support a relaxing sleep in case it might be loud outside. And, in addition, thanks to the anti-burglary effect of shutters, they can increase the feeling of security in your home.

Exterior and interior blinds offer very flexible privacy protection and thermal insulation as they are not only moved up and down, but also the position of the slats can be adjusted. This also provides precise regulation of the amount of light that comes into a room. They are available in a large number of variants, offering lots of space for individual design possibilities. In addition, they can be adjusted even to unusual window sizes.

Awnings protect your terrace or conservatory against excessive solar radiation, offering comfortable stay even on hot summer days. In addition, rain-resistant awnings offer protection also against rain and thus make it possible to stay outside even during unfavourable weather conditions. Awnings are available in a large number of different designs and can therefore be perfectly adjusted to the individual surroundings.

9.2 Installation planning

Which kind of shutters/blinds can be controlled using the Homematic IP Shutter and Blind Actuators?

All kind of shading elements that are provided with an electronic tube motor drive and offer a conventional series switch or two wires (one for moving up, one for moving down) can be controlled comfortably with the Homematic IP Shutter and Blind Actuators.

Please note while planning your installation, that **Homematic IP Shutter Actuators** can only be used for controlling the height of shutters and the degree of extensions for awnings.

The **Homematic IP Blind Actuators** offer this function as well, while also making it possible to adjust the slat position of interior blinds or exterior blinds for outside areas.

How can Homematic IP Shutter and Blind Actuators be controlled?

Depending on the size of your system, Homematic IP offers various possibilities for automatic control of your shading elements. When using Homematic IP Shutter and Blind Actuators, you can replace your existing switch by intelligent wireless solutions. Existing rockers and frames of brand switch manufacturers can continue to be used with corresponding adapters. However, you can still control your shutters, blinds and awnings by **conventional switches**. Furthermore, it is possible to move your shutters up or down comfortably via **remote control**, even without having to get up from your chair.

Shutter profiles in the app enable time-dependent automatic control, if required also depending on the sunrise or sunset.

Via **shutter groups**, comfortable simultaneous control of selected or even all shutters and blinds can be realised via the app.

Even if you are away from home, you can control your awnings, blinds and shutters via the Homematic IP **app** on your **smartphone** at any time. In this way, you will always have ideal shading conditions when coming home. Automatic and manual control via the app make the house look inhabited even if you are not at home and thus control the security in the own four walls.

Added comfort is given by **voice control** for shutters and blinds in connection with different voice control services.

Is it possible to retrofit existing shutter solutions with Homematic IP Shutter and Blind Actuators?

Yes, retrofitting with Homematic IP actuators is possible. The Homematic IP shutter control solution can be realised not only in new buildings or while planning to retrofit the house e.g. with new blinds. Also, existing shutter solutions that are controlled via conventional push-buttons can easily be retrofitted by a smart wireless solution. Therefore, you only have to replace the existing push-button or expand it using a flush-mount module.

How can I combine the shutter and blind actuators with other Homematic IP components?

You can comfortably extend the functions of your shutter and blind control with other Homematic IP devices and adjust it to your individual needs.

By integrating the **Homematic IP Window Contacts** into your system you will be able to activate the **lockout protection**. If balcony or terrace doors are opened, it is avoided that shutters and

blinds are moved down automatically as they are controlled based on time or astro profiles (see sec. „9.6.1 Lockout protection“ on page 153).

Homematic IP Wall Thermostats detect the exact room temperature at all times. If desired, shutters and blinds are moved down automatically via the **heat protection function** that protects a room from overheating (see sec. „9.6.3 Heat protection“ on page 155).

To increase the security in your home, it is recommended to install **Homematic IP Smoke Alarms** as well. In combination with Homematic IP Shutter and Blind Actuators, the **escape function** makes sure that all shutters and blinds are automatically raised in case of smoke alarm (see sec. „9.6.4 Escape function“ on page 157).

9.3 Starting operation of shutter and blind actuators

To integrate your shutter/blind actuator into your system and enable it to communicate with other Homematic IP devices, you must teach-in the device to your Homematic IP Access Point first (see sec. „5.3 Teaching-in devices“ on page 32). Afterwards, the automatic calibration run is carried out to adjust your shutter/blind.

9.3.1 Calibration run

9.3.1.1 Automatic calibration run (for HmIP-BROLL and HmIP-BBL)

After you have entered a name for your shutter/blind and allocated it to a room, you will get to the menu item "Automatic calibration run". The calibration run will determine how long your shutter/blind needs to move up or down completely.



Please note that the automatic calibration run is only available for the Homematic IP Shutter Actuator for brand switches (HmIP-BROLL) as well as the Homematic IP Blind Actuator for brand switches (HmIP-BBL).



The settings for the blind height is automatically corrected via the actuators. With certain slats positions it may happen that the set blind height of 0 % or 100 % cannot be adjusted as required. This is because in some cases the actuator must automatically adjust the blind height so that the desired slats position can be set.



The movement times determined during the manual calibration run also include the motor delay time. This extends the actual movement time from the upper to the lower end position and vice versa by the motor delay time. This has an effect on the settings of the blind height, as this is derived from the movement time. Adjust the times if necessary in the menu item "Compensation for delay of motor start".



Figure 76: Screenshot automatic calibration run

- Tap on "Continue". The automatic calibration run will be started.
- After the automatic calibration run has been successful, tap "Done". Finally, the movement times have been detected.



Please make sure that you do not use your app or the device during automatic calibration run.

9.3.1.2 Manual calibration run

Alternatively, the automatic calibration run you can determine the movement time of your shutters/blinds automatically. When using a Homematic IP Shutter Actuator – flush-mount (HmIP-FROLL) or Homematic IP Blind Actuator – flush-mount (HmIP-FBL) the calibration run is carried out manually as default. To do this, proceed as follows:

- In the menu item "Calibration run" tap on "Manually".



Figure 77: Screenshot selecting manual calibration run

- Tap on "Continue". Your shutter/blind is moved to the initial position (completely darkened). If the initial position is reached and the motor stops, tap "Continue".
- Tap on "Start". Your shutter/blind is moved up completely. If the run is finished, confirm the time that is needed for the brightening run right after the motor is switched off by pressing the "Stop" button. Tap on "Continue".

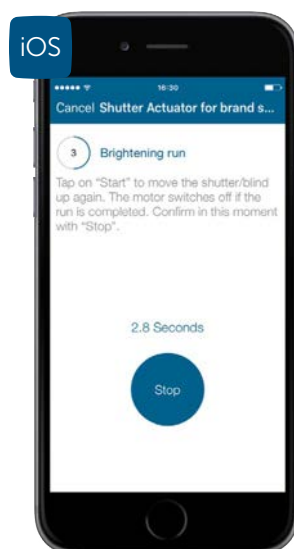

Figure 78: Screenshot brightening run

- To detect the time needed for the darkening run, tap on "Start". Your shutter/blind is moved down completely. If the run is finished confirm the time that is needed for the darkening run right after the motor is switched off by pressing the "Stop" button. Tap on "Continue".
- In the following window, the detected movement times are displayed. Tap on "Continue". The movement times are transmitted to the actuator as soon as the calibration is finished in the next window by tapping "Done".
- You still have the option to adjust the movement times manually. The data is transferred after tap on "Done" or "Confirm".



Figure 79: Screenshot adjusting movement times manually



Tap the "Direct entry" button in the menu item (manual) "Calibration run" to directly enter the movement times for the darkening and brightening run. Tap "Confirm" to save the selected movement times directly. In the following window, you can finish the calibration with a tap on "Finish".

9.3.2 Device settings

9.3.2.1 Assignment

Here, you can subsequently change the room allocation of the device, the device name as well as the calibration run.

9.3.2.2 Movement times

Here, you can change the movement times of your shutter/blind subsequently. This is the time that is required for your shutter/blind to completely move up (brightening run) or down (darkening run).

9.3.2.3 Slats movement time

Adjust the time that is required for completely changing the slats position of the blinds.

9.3.2.4 Delay for changing the movement direction

Here, you can subsequently define the delay time that is at least needed for your shutter/blind to change the movement direction.

9.4 Shutter groups

With the function "Shutter groups" you can summarise shutter actuators in the app. All shutters/blinds allocated to a group that are controlled via the selected shutter/blind actuators can be moved to their pre-defined position (up/down) at the push of a button.

9.4.2.1 Creating shutter groups

- In the main menu, select "Groups" in the menu item "Light and shade".
- Afterwards, tap on the + icon and select "Shutter group".

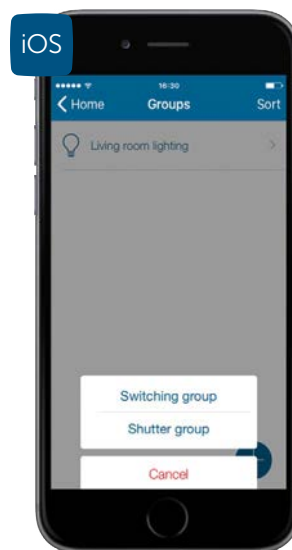

Figure 80: Screenshot selecting shutter group

- Enter the name of the shutter group. Tap "Continue".
- Select the shutter/blind actuators that you want to combine to a shutter group. Tap "Continue".
- Please select the devices for switching this shutter group. Tap "Done" (iOS) or "Continue" (Android).
- Define in the next step the upper position to which the shutter/blind is moved after short button press of the button "Up". Tap "Done".

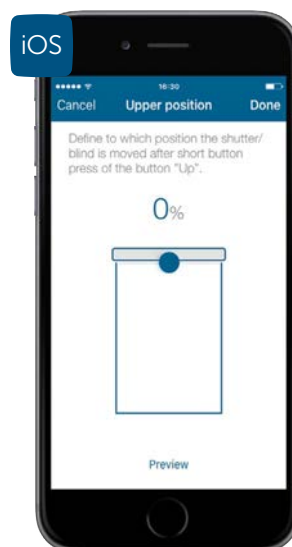

Figure 81: Screenshot defining the upper position

- Define in the next step the lower position to which the shutter/blind is moved after short button press of the button "Down". After tapping "Done", the configuration of the shutter group is finished.

9.4.2.2 Manual control of shutter elements in groups

- In the homescreen of the app, tap on "Groups" and select the desired shutter group.

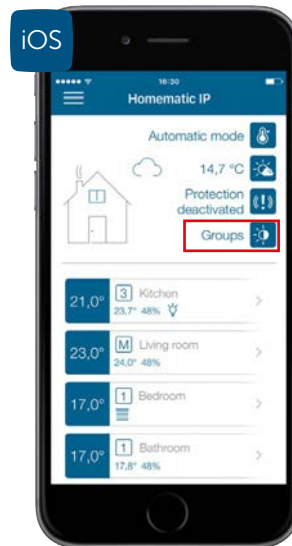

Figure 82: Screenshot group control in the homescreen

- Here you can define the shutter level of all shutters and blinds that are combined in this room.

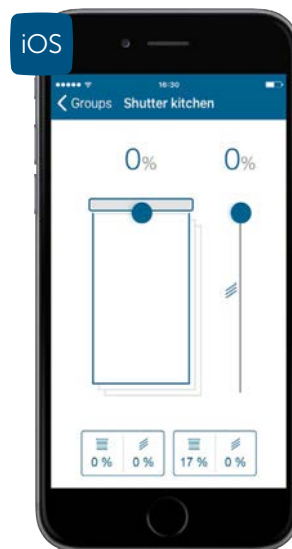

Figure 83: Screenshot switching the shutter group

9.5 Shutter profiles

Via the Homematic IP app you can create individual shutter profiles and control your shutters/blinds flexibly according to your needs - even depending on the sunrise and sunset.

9.5.2.1 Adjusting the time profile

- In the main menu, select "Time profiles" in the menu item "Light and shade".
- Afterwards, tap on the + icon and select "Shutter profile".

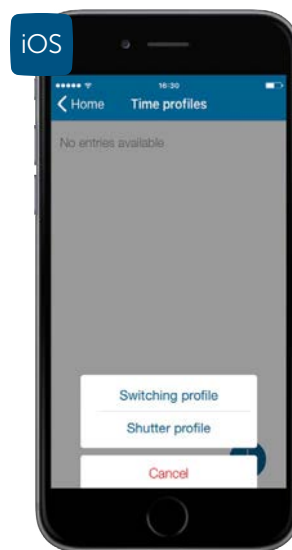

Figure 84: Screenshot creating a shutter profile

- Enter the name of the shutter profile. Tap "Continue".
- Afterwards, tap on the + icon and select all shutter and blind actuators that you want to allocate to this shutter profile. After finishing your selection, tap "Continue".

Selection "Switching time"

- In the overview, select the menu item "Time profile" and tap on the + icon afterwards.
- In the following window select "Switching time" and tap on "Switching time" (iOS) or "Confirm" (Android).
- Select the weekday(s) to which to the corresponding switching time should be applied.

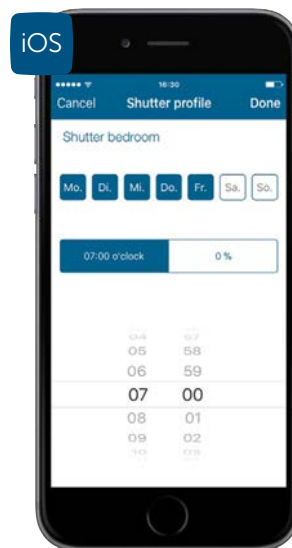

Figure 85: Screenshot adjusting the shutter profile

- Afterwards, select the switching time and the shutter/blind level to which your shutter or blind should be moved. If your blinds are controlled by a blind actuator you can also exactly adjust the slats position of your blind for the defined switching times.

Selection "Sunrise" / "Sunset"

You can also add a time-dependent condition to your set switching times:

- **No condition:** If you select the option "Sunrise" or "Sunset" for your shutter profile instead of a switching time, your shutter/blind is moved to the defined position at sunrise/sunset, if you have selected the option "No condition".
- **Not earlier than:** If you select the option "Not earlier than", your shutter/blind is moved into its defined position at sunrise, but not earlier than the selected point in time. Alternatively you can define, how many minutes before or after the sunrise your shutter/blind is moved into its defined position, e.g. 30 minutes before sunrise, but not earlier than 06:00 o'clock.
- **Not later than:** If you select the option "Not later than", your shutter/blind is moved into its defined position at sunset, but not later than the selected point in time. Alternatively you can define, how many minutes before or after the sunset your shutter/blind is moved into its defined position, e.g. 30 minutes after sunset, but not later than 21:00 o'clock.

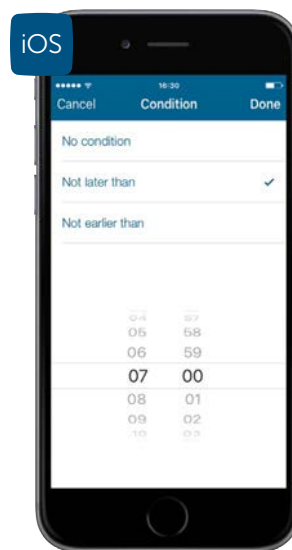

Figure 86: Screenshot selection of condition

After configuration of the shutter profile you can create additional shutter profiles with a tap on the + icon.

9.6 Shutter configuration

After teaching-in the shutter and blind actuators (see sec. „5.3 Teaching-in devices“ on page 32) you can adjust the configuration of your shutter/blind components in the main menu via “Light and shade” in the menu item “Shutter configuration”.

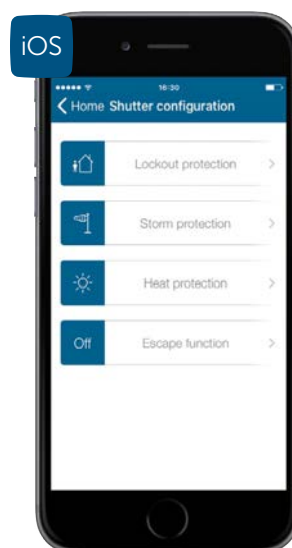

Figure 87: Screenshot shutter configuration

To be able to use the functions for shutter configuration, the following components are required:

- **Lockout protection:**
Homematic IP Shutter or Blind Actuators as well as Homematic IP Window/ Door Contact or Window Handle Sensor
- **Storm protection:**
Homematic IP Shutter or Blind Actuators as well as wind data via the location in your app or detected by weather sensors
- **Heat protection:**
Homematic IP Shutter or Blind Actuators as well as Homematic IP Wall Thermostat or Temperature Sensor
- **Escape function:**
Homematic IP Shutter Actuator or Blind Actuator as well as Homematic IP Smoke Alarm



Please note that for the functionalities lockout protection, storm protection, heat protection and escape function your Homematic IP system has to be fully operational. This implies the Homematic IP Access Point with active connection to the Homematic IP cloud and the corresponding Homematic IP devices that are integrated into the installation.

9.6.1 Lockout protection

If balcony or terrace doors are opened, the lockout protection avoids that shutters and blinds are moved down automatically as they are controlled based on time or astro profiles. This is useful for example if you are outside on the terrace for a longer time and you want to avoid unintended lockout in case your shutter is moved down.

A Homematic IP Window Contact or Window Handle Sensor mounted to the corresponding door or window detects whether the door/window is open. In this way it is made sure that shutters or blinds are not moved down.



Please note that lockout protection does not avoid moving down of shutters and blinds if moving down has been triggered manually (via a push-button or remote control, for example) or via automation rules.

To activate the lockout protection, please proceed as follows:

- In the menu item "Shutter configuration", tap "Lockout protection".
- Select the actuator(s) that control(s) the shutter or blind, for which you want to activate the lockout protection with a tap on the + icon.
- Tap on the + icon and allocate the shutter or blind actuator to the window or door contact or the window handle sensor that activates the lockout protection and thus avoids moving down of shutters or blinds.
- Tap "Done" to finish the configuration of the lockout protection.

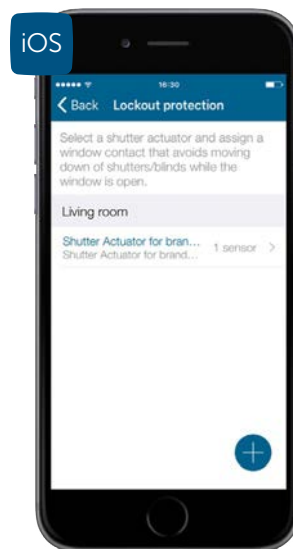

Figure 88: Screenshot lockout protection



Please note that skipped switching times will not be repeated.

9.6.2 Storm protection

In case of strong wind it is important - also for insurance reasons - to protect shutters, awnings and blinds as well as windows effectively from any damages caused by the weather.

Depending on the wind resistance class of the blinds installed, they must be moved up completely in case of storm. Standard shutters can be moved down in case of strong wind to protect the windows from storm damages.

The storm protection function integrated in the Homematic IP app makes sure that this is carried out automatically as soon as the selected wind threshold value is exceeded. The current wind velocity value is obtained by the app via the weather data that is defined in the app for the online service OpenWeatherMap for your location or via Homematic IP weather sensors.



Set the location in your app to enable correct data collection for your installation. Tap in the menu on "Settings" and there on "Location + Time zone" to adjust the settings for your location and postcode.

To activate the storm protection function, please proceed as follows:

- In the menu item "Shutter configuration", tap on "Storm protection".
- Tap on the + icon to select the shutter actuator(s) that you want to activate for the storm protection.

You can adjust further settings for the storm protection afterwards.

- Via the button "Wind sensor - Online weather data" you can define the data source for the detection of the wind threshold value. In the default settings, these are based on the weather data collected in the app for your location via OpenWeatherMap. If you have installed a wind/weather sensor, also this data source can be selected.
- Tap on the button "Wind threshold value". Select the wind threshold value at which

the shutter or blind should be moved if the threshold is exceeded. Afterwards, tap "Done" or "Confirm".

- Select the movement direction. When selecting "move up", the shutter or blind is moved up, when selecting "move down" the shutter is moved down. After tap on "Done" or "Confirm", the configuration of the storm protection is finished.

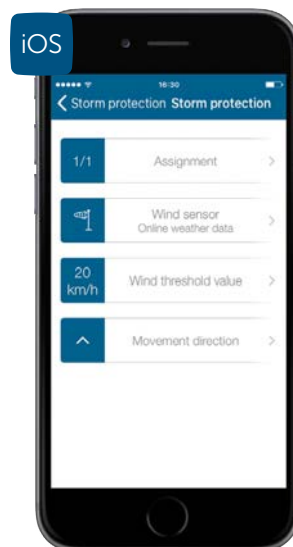

Figure 89: Screenshot configuration of storm protection

If the value falls below the defined wind threshold the shutters and blinds remain in the position where it has moved to during storm protection until the next switching time of the time profile.



If lockout protection or the escape function have been activated the storm protection cannot be activated.



Please note that the wind velocity of the online service may differ from the current weather conditions at your location as the data is based on calculations of the nearest measuring stations and is not updated live.



Please note that skipped switching times will not be repeated.

9.6.3 Heat protection

The heat protection function enables automatic control of shutters and blinds to avoid or reduce unintended heating of rooms due to strong sunlight. In this way, your rooms remain cold also during summer. When exceeding an adjustable temperature threshold value, shutters, awnings or blinds are moved into a predefined position. In addition, you can define in which time period the heat protection will be activated, e.g. to avoid that shutters are moved up during night.

To activate the heat protection function, please proceed as follows:

- In the menu item "Shutter configuration", tap on "Heat protection".
- Tap on the + icon and select one or more rooms to configure the heat protection. Only rooms are displayed that include the necessary devices. Tap "Done" or "Confirm".

You can adjust further settings for the heat protection afterwards.

- The function "upper threshold value" can be used to define from which degree (Celsius) the shutter or blind is moved into the position defined.
- The function "lower threshold value" can be used to define at which room temperature the shutter or blind is moved into the previously set normal position.
- Tap "shutter position" to define the value in percent to which the shutter or blind is moved.
- In the menu item "valid from or valid until" you can define in which period of time the heat protection is activated. You can either select "Sunrise" or "Sunset" so that the heat protection starts with the sunrise or sunset that currently applies for your location. Alternatively, select a time here.
- After tap on "Done" or "Confirm", the configuration of the heat protection is finished.



The time profile is active simultaneously and, like manual operation, has priority over the settings of the heat protection.



If lockout protection, storm protection or the escape function have been activated, the heat protection cannot be activated.

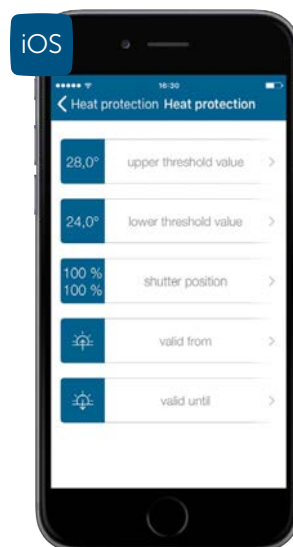

Figure 90: Screenshot configuration of heat protection

9.6.4 Escape function

The escape function can be used to automatically move up all shutters and blinds in case of smoke alarm. Thus, in case of emergency the escape route through a terrace door is not blocked e.g. by shutters.

To activate the escape function, please proceed as follows:

- Tap "Shutter configuration" and "Escape function".
- Tap "Activate" and afterwards on "Done" (iOS) or "Confirm" (Android). You can also deactivate the escape function afterwards.

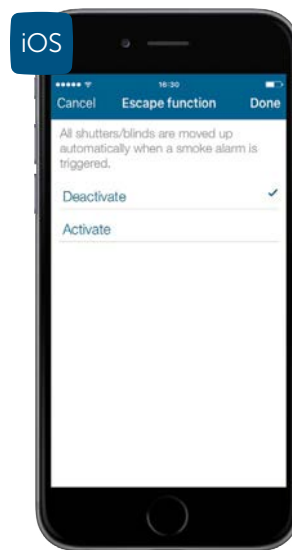

Figure 91: Screenshot activation of escape function



Please note that skipped switching times will not be repeated.

10 LIGHT CONTROL

Comfortable switching and dimming of lights creates a sense of well-being in your home. Thus, a comfortable atmosphere for your TV evening is created via the app as the ceiling light is dimmed to a desired brightness level while the floor lamp is switched on. Also, the sense of security is increased with an illuminated driveway or house façade in the evening. Individual week profiles can be created as well, enabling time-controlled switching and dimming of lights. Another additional function in the app is for example also offered for gradual dimming of the light sources from 0 to 100 % within 20 minutes for a gentle start into the day. Homematic IP products for brand switches can easily be integrated into the installations of your home since existing frames and rockers can continue to be used.

10.1 Installation planning

The Homematic IP switching and dimming actuators offer various possibilities for light installations in your home. With different designs, the devices can be flexibly integrated and afterwards be controlled via smartphone, remote control push-button or via motion and presence sensors.

Is it possible to integrate the devices into my existing installation?

Retrofitting of switch, metering and dimming actuators with Homematic IP is easy and flexible thanks to different designs like pluggable switches or flush-mounting devices.

Special comfort is offered when using switch and dimming actuators for brand switches (HmIP-BSM and HmIP-BDT). The adapters for different switches allow you to replace switches made by popular manufacturers with an intelligent Homematic IP installation. Using the components of existing or planned switches and cabling reduces the installation costs to a minimum. The design, colour and surfaces of switches that have already been installed does not change, since the existing frames and rockers can continue to be used.

Homematic IP switch actuators can be used not only in inside rooms but also in outdoor areas. Simply mount e.g. the Homematic IP Switch Actuator and Meter – flush-mount (HmIP-FSM) into an appropriate surface-mounting box (e.g. Abox 025 or Abox 040).

Which light sources can be dimmed with the Homematic IP Dimming Actuator?

The dimming actuators allow dimming of standard incandescent lamps, HV and LV halogen lamps (with electronic transformer) and dimmable energy-saving lamps as well as dimmable LEDs.

10.2 Configuration of the light solution

After teaching-in the light components (see sec. „5.3 Teaching-in devices“ on page 32) select the option “Light” to allocate your devices to the light solution.



For devices that are used for the light solution only, this step is skipped as the device is assigned automatically.

The subsequent configuration of your light solution is done via the main menu, "Light and shade" via the menu item **Groups** and **Time profiles**.

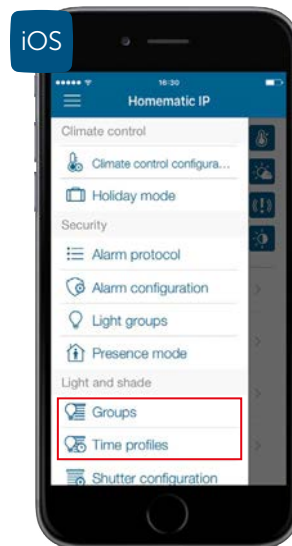

Figure 92: Selecting the assignment to a solution

10.2.1 Switching groups

With the function "Switching groups" you can combine devices like the Homematic IP Pluggable Switches, Motion Detectors or Switch Actuators and Meter into groups. All devices that are allocated to a group can afterwards be switched on and off at the push of a button. Furthermore, light sources that are controlled with Homematic IP Dimming Actuators can be dimmed to a certain dimming level.

10.2.1.1 Creating a switching group

- Tap in the app homescreen on the main menu icon (☰) (Android) or (☰) (iOS) and select "Groups" under "Light and shade" in the main menu.
- Afterwards, tap on the + icon and select "Shutter group". Enter the name of the switching group.

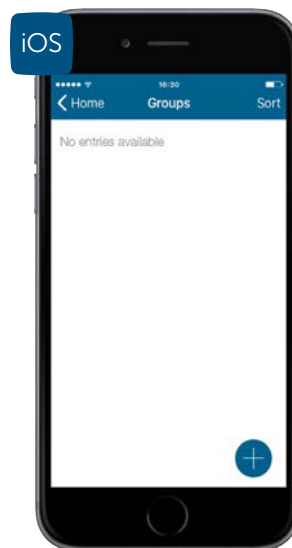

Figure 93: Screenshot creating a switching group

- Tap on "Return" (iOS) or "Enter" (Android) and afterwards on "Continue".
- Tap on the + icon and select one after the other all devices you want to allocate to this switching group (receivers).
- After finishing your selection, tap "Continue".
- Afterwards, select the devices for switching your switching group (triggers, e.g. motion detector).

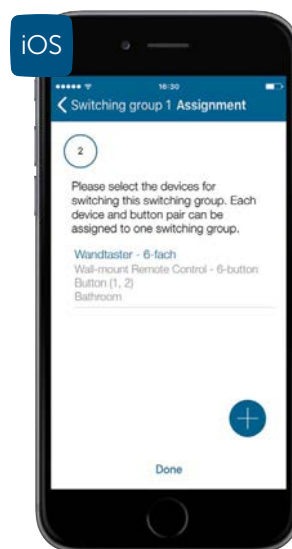

Figure 94: Screenshot selecting trigger for switching group



Each device and button pair can be assigned to one switching group only.

- Confirm the system button of all triggering devices to confirm the configuration. Afterwards, tap "OK".

10.2.1.2 Rename or delete switching groups

- Tap in the app homescreen on the main menu icon (☰) (Android) or (☰) (iOS) and select in the main menu "Groups".
- Afterwards, select the switching group by pressing the switching group for a longer time (Android) or swipe from right to left (iOS).
- Tap the pen-icon in the headline (Android) or "Rename" (iOS), enter the new name of the switching group and tap "Confirm".
- For deleting a switching group, tap "Delete" and confirm afterwards.

10.2.1.3 Selecting the dimming value

If one or more dimming actuators are integrated into a switching group, you can use the menu item "Dimming value" to adjust the dimming value for all dimming devices of this group.

- In the menu "Groups" select the desired switching group by tapping on it.
- Tap "Dimming value" and select the dimming value using the control dial. Furthermore, you can switch the actuators to the last dimming value used.
- Tap "OK" (Android) or "Done" (iOS).

10.2.1.4 Defining the switch-on time

- In the menu "Groups" select the desired switching group by tapping on it.
- Tap "Switch-on time" and select the time (1 second to 30 hours or continuously).
- Tap "OK" (Android) or "Done" (iOS).



Figure 95: Screenshot selecting trigger for switching group

10.2.2 Switching profiles

With the “Switching profiles” functions you can set up time profiles for your light control. In this way, you can switch on and off e.g. switching actuators in certain periods of time or depending on the sunrise and sunset. Furthermore, you can use dimming actuators to dim lights for a defined duration to a desired brightness value.

10.2.2.1 Creating switching profiles

- Tap in the app homescreen on the main menu icon (☰) (Android) or (☰) (iOS) and select in “Light and shade” “Time profiles” in the main menu.
- Afterwards, tap on the + icon and select “Switching profile”. Enter the name of the switching profile.
- Tap “Return” (iOS) or “Enter” (Android) and afterwards on “Continue”.
- Tap the + icon and select one after the other all devices you want to allocate to this switching profile.
- After finishing your selection, tap on “Continue”.



Each device and button pair can be assigned to one switching profile only.

- You can now adjust further settings for time your profile afterwards. Tap “Time profile” to set-up the switching times and dimming values.

Selection “Switching time”

- In the overview, select the menu item “Time profile” and tap on the + icon afterwards.
- In the following window select “Switching time” and tap on “Switching time” (iOS) or “Confirm” (Android).
- Select the weekday(s) to which to the corresponding switching time should be applied.

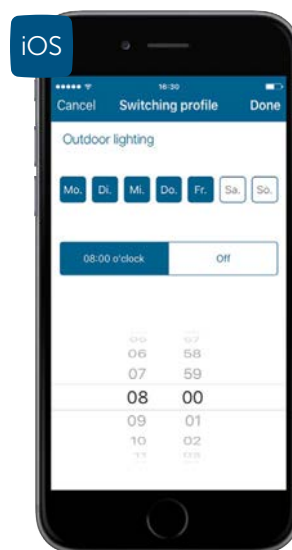

Figure 96: Screenshot adjusting the switching profile

- Afterwards, select the switching time and the switching status (on/off) of your actuator to the selected switching time.

Selection "Sunrise" / "Sunset"

You can also add a time-depended condition to your set switching times:

- **No condition:** If you select the option "Sunrise" or "Sunset" for your switching actuator instead of a switching time, your actuator is switched into the defined status at sunrise/sunset, if you have selected the option "No condition".
- **Not earlier than:** If you select the option "Not earlier than", your actuator is switched into its defined status at sunrise, but not earlier than the selected point in time. Alternatively you can define via "Time offset", how many minutes before or after the sunrise your actuator starts switching, e.g. 30 minutes before sunrise, but not earlier than 06:00 o'clock.
- **Not later than:** If you select the option "Not later than", your actuator will start switching at sunset, but not later than the selected point in time. Alternatively you can define via "Time offset", how many minutes before or after the sunset your actuator starts switching, e.g. 30 minutes after sunset, but not later than 21:00 o'clock.

The following example presents a switching profile for outdoor lighting, that is switched on from Monday to Friday from sunset to 23:00 o'clock, but not before 19:00 o'clock:



Figure 97: Screenshot example outdoor lighting

After configuration of the switching profile you can create additional time profiles with a tap on the + icon.

10.2.2.2 Additional information for switching with motion detectors/presence sensors

Motion and presence sensors are available as triggering devices for switching groups only if the device has been allocated to the "Light and shade" application has been selected.



If the switching group is switched via a motion detector or presence sensor the switch-on time should be at least 4 minutes.

- Due to the integrated brightness sensor, the brightness threshold value of the motion detector or presence sensor can be adjusted in the app. Select a value between 0 and 255. A low value means that the motion detector or presence sensor switches on only during darkness. In case of a high value it reacts also during daylight. In addition, you can take over the current brightness value of the sensor as brightness threshold.

10.2.3 On/off control of groups in the homescreen

The “Groups” button in the homescreen of the app allows quick access to all switching and shutter groups of your system. Via this menu item, you can switch on and off all devices of your switching group at the same time.



Figure 98: Screenshot switching groups homescreen

10.2.4 On/off control in the menu item “Light”

The menu item “Light” can be used to switch light sources and other connected loads in selected rooms on and off: Devices like a floor lamp that are connected to a Homematic IP Pluggable Switch or Switch and Meter can be switched comfortably via the Homematic IP smartphone app, no matter if you are at home or out and about.

- Select the room including the device(s) you want to switch on or off in the homescreen of the app.
- Swipe the semicircle in the middle right side of the screen to the left and tap “Light”.



Figure 99: Screenshot selection of "Light"

- In the menu item "Light" you can switch on or off the devices that are listed via the buttons – either all devices or each device separately.

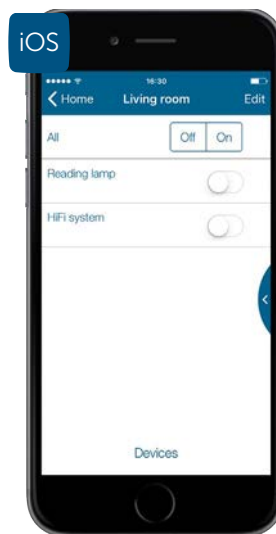

Figure 100: Screenshot light control on/off

- After you have switched on the lights, you can swipe the semicircle again to the left and select another solution.

11 GROUPS, TIME PROFILES AND AUTOMATION

Apart from the basic functions, your Homematic IP system offers a wide range of possibilities for facilitating the device control. With the **“Group”** function of the app it is possible to combine devices like Homematic IP Pluggable Switches, Motion Detectors or Switch Actuators and Meter into switching groups and to switch devices on or off after the detection of motion, for example. You can also group shutters and blinds into shutter groups and comfortably control your actuators at the push of a button.

With the **“Time profiles”** function for light and shutter control you can switch on and off e.g. switching actuators in certain periods of time or depending on the sunrise and sunset. Furthermore, you can use dimming actuators to dim lights for defined duration to a desired brightness value. The same applies to the **“Shutter profiles”** function.

Also voice control with Amazon Alexa or Google Assistant offer the possibility to comfortably use heating, light or shutter control as well as activating of alarm functions by setting-up device groups.

For all functionalities that cannot be set up via groups nor via time profiles the **“Automation”** function can be used. You can use the **“Automation”** of the Homematic IP app to automate numerous tasks within your Homematic IP system. Operations can be connected across all solution variants (light control, heating control, security, etc.).



In contrast to time profiles and groups that remain activated even without Internet or cloud connection, active Internet connection is required for the “Automation” function as the automation rules are verified via the Homematic IP cloud.

11.1 Setting up automations

For the automation of tasks, it is necessary to create rules. These rules always include at least one trigger and one action that starts if the condition for the trigger(s) is/are fulfilled, e.g. if a room temperature falls below a certain threshold value. Furthermore, the function offers the possibility to define additional conditions that must be fulfilled to introduce the action desired.

11.2 Activation and deactivation of automations

In the default settings, all automations defined by you are activated and will be executed in case of an active Internet connection. However, you can deactivate and activate the automations at any time if required.

- To activate or deactivate the automation, open the corresponding automation. Use the controller “Active” to activate the automation or to deactivate the execution of your automation.

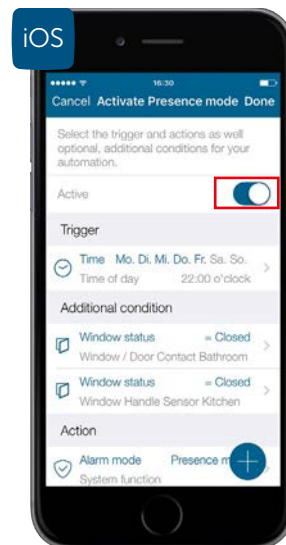

Figure 101: Activation and deactivation of automations

11.3 Application example: Night light in the darkness

With darkness approaching, the Homematic IP Light Sensor – outdoor is used to switch on the lights of both push-buttons of the Homematic IP Switch Actuator with signal lamp, making the actuator an orientation light at night.

Requirements:

- Homematic IP Access Point
- Homematic IP Light Sensor – outdoor
- Homematic IP Switch Actuator – with signal lamp
- active Internet connection

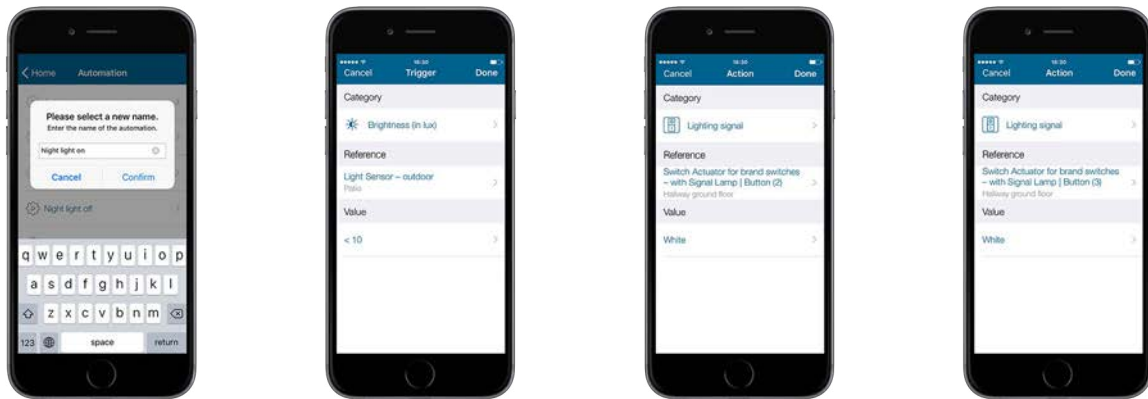

Figure 102: Example of automation: Night light in the darkness on

- Tap on the main menu icon in the homescreen and there on "Automation".
- Tap the + icon at the lower edge of the screen and enter a name for your automation into the empty field of the pop-up window, e.g. "Night light on".
- Tap "no trigger selected".
- In "Category", tap on "Brightness (in lux)".
- Select "Light Sensor – outdoor" in the "Reference" field.
- Under „Value“, select "< 10", for example. Tap the arrow at the top left of the screen (Android) or "Done" (iOS).
- Select the following actions:
 - Under "Category" select "Lighting signal", under „Reference“ select the button (2) of the switch actuator for brand switches with signal lamp. Under "Value" select e.g. "White" as lighting signal.
 - With an additional action, you can use the same settings for the lower button (3) of the switch actuator.

After tap on "Confirm" (Android) or "Done" (iOS) the automation is saved. Your night light is switched on automatically when darkness sets in.

With a second automation, the night light is automatically switched off, when it is bright again.

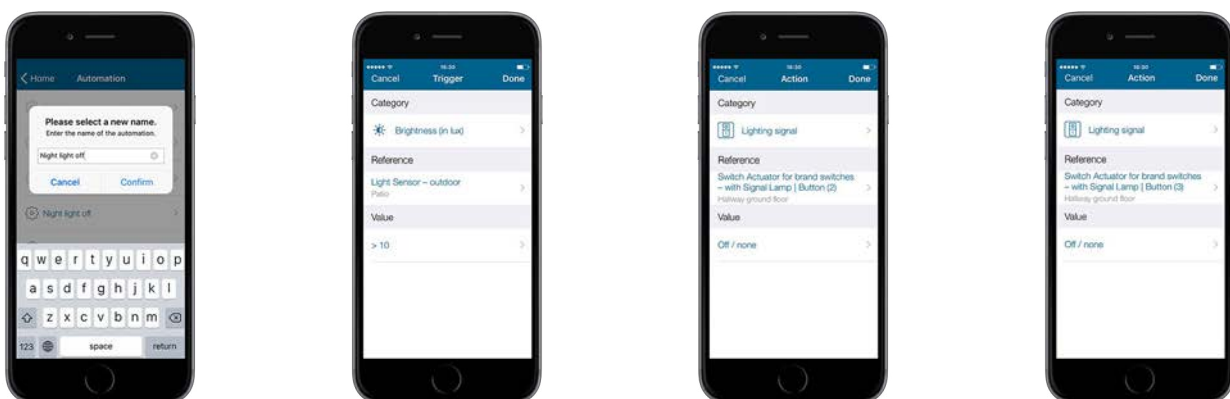

Figure 103: Example of automation: Night light during brightness off

To do this, proceed as follows:

- Tap on the main menu icon in the homescreen and there on "Automation".
- Tap the + icon at the lower edge of the screen and enter a name for your automation into the empty field of the pop-up window, e.g. "Night light off".
- Tap "no trigger selected".
- In "Category", tap on "Brightness (in lux)".
- Select "Light Sensor – outdoor" in the "Reference" field.
- Under „Value“, select "> 10", for example. Tap the arrow at the top left of the screen (Android) twice or "Done" (iOS).
- Select the following actions:
 - Under "Category" select "Lighting signal", under „Reference“ select the upper button (2) of the switch actuator for brand switches with signal lamp. Under "Value" select "Lighting signal" "Off / none".
 - This action is also needed for the lower button (3) of the switch actuator.

After tap on "Confirm" (Android) or "Done" (iOS) the automation is saved. Your night light is switched off automatically when brightness sets in.

11.4 Application example: Signal for bathroom occupied/free

A Homematic IP Switch Actuator – with signal light mounted in the hallway is used to indicate whether the bathroom is occupied or free. At the same time, the light is switched on if a person is present and off, if no motion is detected.

Requirements:

- Homematic IP Access Point (HmIP-HAP)
- Homematic IP Switch Actuator – with signal lamp (HmIP-BSL)
- Homematic IP Presence Sensor – indoor (HmIP-SPI)
- suitable Homematic IP Switch Actuator for switching the ceiling light in the bathroom
- active Internet connection

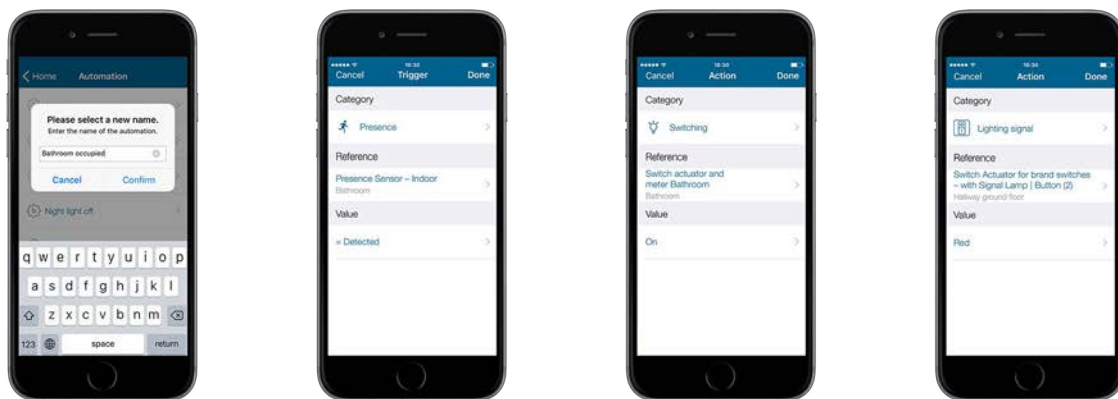

Figure 104: Example of automation: Bathroom occupied

- Tap on the main menu icon in the homescreen and there on "Automation".
- Tap the + icon at the lower edge of the screen and enter a name for your automation into the empty field of the pop-up window, e.g. "Bathroom occupied".
- Tap "no trigger selected".
- Select "Category" and tap on "Presence".
- Select the "Presence Sensor – indoor" in the "Reference" field.
- Under „Value“, select "Detected". Tap the arrow at the top left of the screen (Android) or "Done" (iOS).
- Now select the following actions:
 - Tap on "Actions", "Category" and select "Switching". In the "Reference" field select the switch actuator that you want to use for switching the bathroom light. Under „Value“, select "On". In the field "Switch-on duration" you can specify, for which period the light shall be switched on.

Tap on the plus sign for the second action and select the desired signalling colour.

- Tap "Action" and confirm your selection.
- Under "Category" select "Lighting signal", under „Reference" select the upper button (2) of the switch actuator. Under "Value" you can adjust the brightness, switch-on time, dimming time for switching on the push-button light as well as the signalling colour. Select "red" for example to indicate an occupied bathroom.

After tap on "Confirm" (Android) or "Done" (iOS) the automation is saved. With a second automation, you can deactivate the signalling if no motion is no longer detected in the bathroom. To do this, proceed as follows:

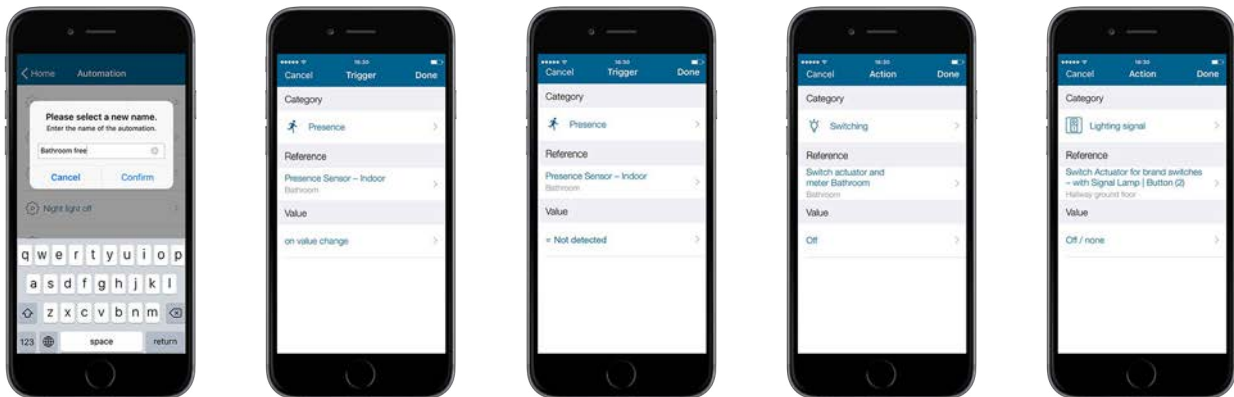

Figure 105: Example of automation: Bathroom free

- Tap on the main menu icon in the homescreen and there on "Automation".
- Tap the + icon at the lower edge of the screen and enter a name for your automation into the empty field of the pop-up window, e.g. "Bathroom free".
- Tap "no trigger selected".
- Select "Category" and tap on "Presence".
- Select the "Presence Sensor – indoor" in the "Reference" field.
- Under „Value“, select "on value change". Tap the arrow at the top left of the screen (Android) twice or "Done".
- Create an additional condition. Select under „Category“ "Presence", under „Reference“ „Presence Detector – indoor" and under „Value“ "Not detected".
- Select the following actions:
 - Tap on "Action", "Category" and select "Switching". In the "Reference" field select the switch actuator that you want to use for switching the bathroom light. Under „Value“, select "Off".

Tap the plus sign for the second action for switching the signal lighting off, if presence is no longer detected.

- Tap "Action" and confirm your selection.
- Under "Category" select "Lighting signal", under „Reference“ select the upper button (2) of the switch actuator. Under "Value" select "Lighting signal" "Off / none".
- After tap on "Confirm" (Android) or "Done" (iOS) the automation is saved.

12 VOICE CONTROL FOR HOMEMATIC IP

12.1 Comfortable voice control for your smart home

The operation of devices or apps via voice control is a growing trend. According to a current Bitkom study, more than half of all smartphone users already use voice commands for controlling different functions like calling of contacts, route planning or note taking, e.g. via Google Assistant or Siri.⁵

Especially in the smart home field, this relatively young technology becomes more and more important with the increased integration of voice control technology. In the middle of 2017, 39 percent of all citizens in Germany over the age of 14 said they would use digital voice assistants for controlling their smart home.⁶ With loud speakers supporting voice control like Amazon Echo or Google Home and the increasing number of connected devices in households, comfortable control using voice commands finds its way into the own four walls.

The connection of Amazon Alexa and Google accounts with your Homematic IP smart home system provides the possibility to control a large number of Homematic IP devices and functions via voice commands in connection with a compatible loud speaker with integrated voice assistant.

Apart from this, you can also use smartphone apps like Google Assistant for controlling your smart home system via voice commands – even without a Google Home loud speaker.

The functionalities supported by Amazon Alexa so far include heating control and the activation of alarm functions as well as light control (switching on/off and dimming) and shutter control (moving shutters up and down). Also activation and deactivation of the eco mode and controlling of switching groups is supported. For security reasons, the alarm functions can be activated via voice command but not deactivated. In the default settings, voice control devices do not execute any voice commands during activated presence or absence mode which apply other functionalities. However, via the Homematic IP app you can adjust your system in that way, that voice commands are executed also during activated presence or absence mode.

Also the Google Assistant app offers various functionalities. Voice control for the German language is continuously improved by Google and may not be available with its complete range of functions at the beginning.

In connection with the Homematic IP app, Google offers switching of switch and dimming actuators (on and off) for light control, dimming and switching of light groups, heating control by adjusting the desired room temperature as well as requesting current settings of the room temperature or activating and deactivating the eco mode. However, also the absence and presence mode can be activated. Also in this case, deactivation is not possible in the standard settings for security reasons.

Requirements for using the voice control

Amazon Alexa:

- Homematic IP system with Homematic IP Access Point and devices that support language control

5 <https://www.bitkom.org/Presse/Presseinformation/Das-Smartphone-gehört-auf-Wort.html>

6 <https://www.bitkom.org/sites/default/files/file/import/170901-CT-Studie-online.pdf>

- Compatible smartphone (Android or iOS) with the current version of the Homematic IP app
- Amazon user account
- Speaker supporting the Amazon voice service (e.g. Amazon Echo, Amazon Echo Dot or Amazon Tap)
- Active Internet and cloud connection

Google Home:

- Homematic IP system with Homematic IP Access Point and devices that support language control
- Compatible smartphone (Android or iOS) with the current version of the Homematic IP app
- Current version of the Google Home app or alternatively the latest version of the Google app (only Android)
- Google account
- Compatible smartphone or tablet (the minimum requirements to the operating system for running the Google Home app must be fulfilled)
- Active Internet and cloud connection
- Google Home device (optional)



Voice control services always require active Internet or cloud connection and should be used with additional direct links to the Homematic IP devices. This ensures secure control of devices even in case of Internet failures.

12.2 Voice control with Amazon Alexa

12.2.1 Setting up Amazon Alexa

- Connect your Alexa-enabled loud speaker via the mains cable to the power supply.
- Download the free Alexa app to your smartphone.
- Start the Alexa app and log into your Amazon account with your login data.

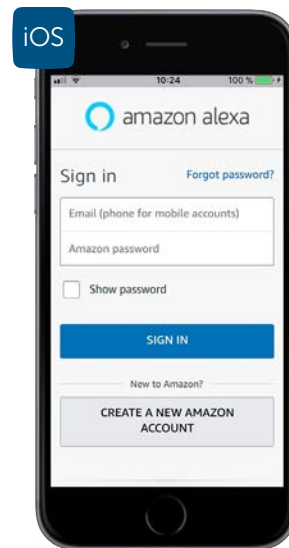



Figure 106: Screenshot Amazon Alexa login

- Tap the device symbol .
- Tap the + symbol at the top right edge of the screen and then "add devices".
- Tap "Amazon Echo", select the device you want to connect from the list and connect your Alexa speaker with the WiFi network. Follow the instructions in the app.
- The message "You've connected to Echo. Go ahead and finish the setup in the Alexa app" appears.
- Tap on "Continue".
- Choose the WiFi and tap on "Connect".
- Tap the "Continue" button if the setup is completed.

12.2.1.1 Connecting your Homematic IP smart home system with Alexa

- Open the Homematic IP app.
- Tap on "Settings" in the menu and select the voice control button. Then, tap on "Amazon Alexa". The activation key for connecting the Amazon Alexa app with the Homematic IP smart home skill is displayed.



Figure 107: Screenshot copying the activation key

- Tap on "Copy" (iOS) or the  icon (Android).

Activate the Homematic IP smart home skill in the Amazon Alexa app:

- In the Alexa app, open the left navigation area and tap on "Skills and games".

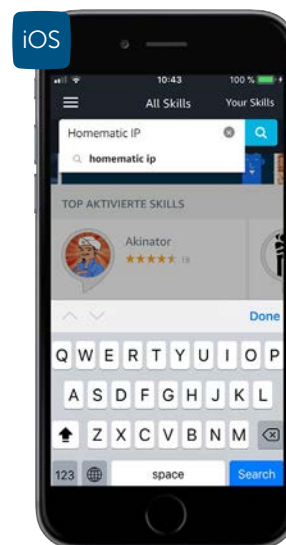

Figure 108: Screenshot searching the Homematic IP skill

- Enter "Homematic IP" into the search box and tap on the search icon.
- Choose the Homematic IP skill by tapping and press the "Done" button afterwards.

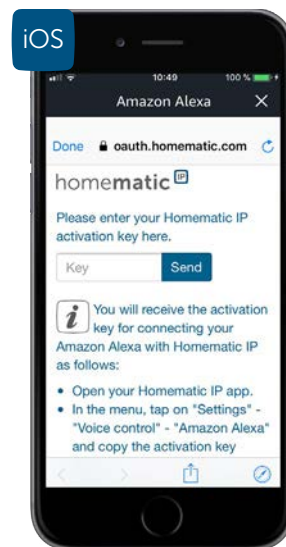

Figure 109: Screenshot entering the activation key

- Enter the activation key into the request field. Therefore, keep the entry field pressed and tap on "Enter".
- Press the "Send" button to establish the account linking.

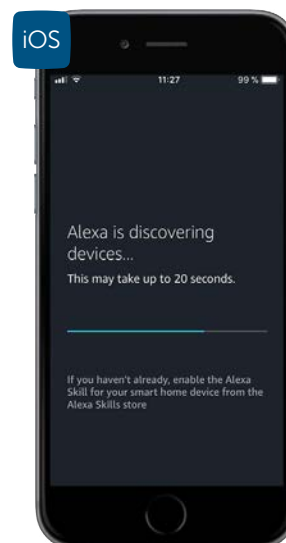

Figure 110: Screenshot searching devices

- Tap "Search devices" or say: "Alexa, search devices!".

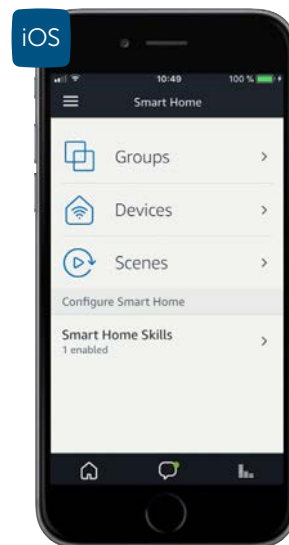

Figure 111: Screenshot skills overview

- In the Alexa app, you will find in the menu item “Smart Home” all groups, devices and scenes that Alexa has found and can control. The descriptions of devices and functions are automatically adopted from the Homematic IP app.

You will now be able to control a large number of functions and devices of your Homematic IP smart home system via voice control.

12.2.1.2 General information about Alexa and Homematic IP

Amazon Alexa-enabled devices only react to voice commands if you say the wake word, e.g.:

“Alexa, set bathroom to 29 degrees.”



The activation word can be changed in the Alexa app.

You should use unique names for all Homematic IP devices, functions and switching groups as well as groups in the Alexa app. Only in this way Alexa will be able to assign them correctly.



Avoid descriptions with a similar beginning. For example, the description “Bedroom light” can be interpreted by Alexa as voice command for a similar heating group that is named “Bedroom” and can thus not correctly allocate the command. In contrary, if you select a description like “Lights bedroom”, this will cause less errors by Alexa.

To avoid confusion with voice commands, you can adjust the device and group names in the Homematic IP app. Refresh the device list in the Alexa app afterwards (see sec. „12.2.1.3 Alexa update of the device list” on page 178).



Please note: Word-letter combinations or word-number combinations like “kitchen 1” may under certain conditions not be processed correctly.

12.2.1.3 Alexa update of the device list

If you have changed names of devices or functions in the Homematic IP app or if you have connected new devices you have to discover devices in the Alexa app again. This is carried out automatically on a regular basis. You can discover new devices by saying "Alexa, discover devices!" or via the app:

- Tap "Devices" and "Discover".

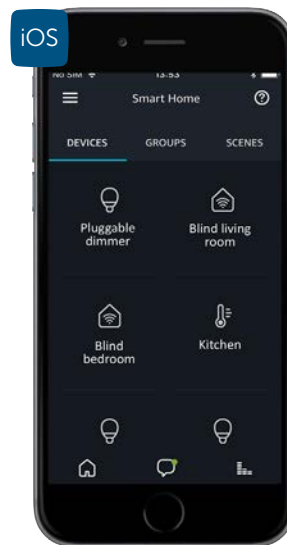

Figure 112: Screenshot skills overview

- With a tap on "Devices" you will find a current list of all groups, devices and scenes that have been discovered by Alexa and can be controlled. Select the device, group or scene you want to delete, tap „Edit“ and afterwards on the basket icon. To confirm, tap „Delete“.



If you have started the device discovery with the voice command "Alexa, discover devices" the new devices will appear in "Devices" if you open the menu item "Smart Home" again.

If you delete Homematic IP devices from your system or change the allocation to a solution, the devices will not automatically be deleted from the Alexa "Devices" list. You need to manually delete the devices in the Alexa app.

- Open the left navigation area in the Alexa app and tap on "Smart Home".

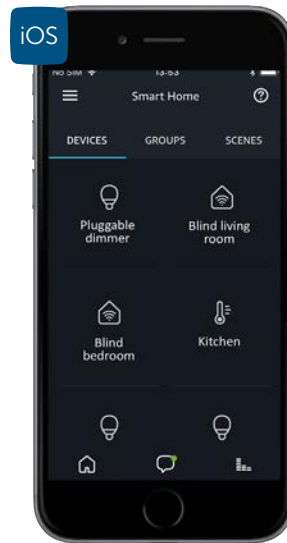

Figure 113: Screenshot Alexa device list

- Scroll through the device list and tap “Forget” to remove a device from your records.

12.2.1.4 Devices and functions supported by Amazon Alexa

The following Homematic IP devices and functions are currently supported:

Device/function	On	Off	Set %	Raise %	Lower %	Set °C	Raise °C	Lower °C	Request temperatures
Switching actuators	✓	✓							
Dimming actuators	✓	✓	✓	✓	✓				
Shutter and blind actuators			✓						
Temperature sensors									✓
Weather sensors									✓
Switching groups	✓	✓							
Heating groups						✓	✓	✓	✓*
Shutter groups			✓						
Presence mode	✓								
Absence mode	✓								
Eco mode	✓	✓							

*Setpoint and actual temperature

12.2.1.5 Voice command examples

When using switch actuators, switch actuators and meter, pluggable switches as well as pluggable switches and meter, you can switch connected devices on and off.

Example:

"Alexa, turn on the bedroom light."

Lights that are controlled by a dimming actuator can be switched on and off as well:

Example:

"Alexa, turn on the living room lights."

Furthermore, lights can be set to a desired brightness value:

Example:

"Alexa, set living room light to 50 percent."

"Alexa, increase living room light by 20 percent."

"Alexa, decrease bedroom light by 40 percent."

Furthermore, shutters and blinds can be moved via voice command to a desired height.

Example:

"Alexa, set bedroom shutters to 50 percent."

Switching groups that have been defined via the Homematic IP app can be switched on and off:

Example:

"Alexa, turn on the ground floor lights."

Security functions like the presence mode or absence mode can be activated via voice command:

Example:

"Alexa, activate the absence mode."

You can also activate or deactivate the eco mode:

Example:

"Alexa, activate the eco mode."

Furthermore, you can request the current actual and setpoint temperature in a room, if a heating group with a temperature sensor is available:

Example:

"Alexa, what is the temperature in the living room?"

12.2.1.6 Alexa smart home device groups

In the Alexa app, you can organise your devices or switching groups into groups and control all devices of a group via voice command. For example, several rooms can be allocated to a group. In this way, you can e.g. adjust the temperature in all rooms of the ground floor at the same time.

- Open the left navigation area in the Alexa app and tap on "Smart Home".

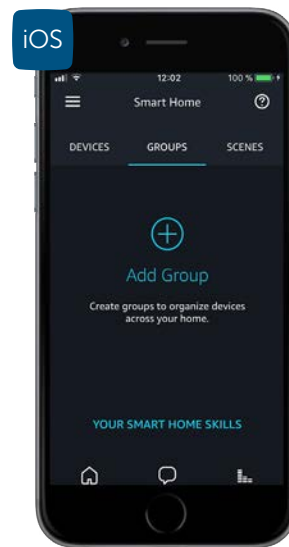





Figure 114: Screenshot groups overview

- Select "Groups" and then "Create groups".
- Enter the name of the group into the text box, e.g. "Heating entire house".
- Use the check box to select the "devices" that you want to use for your group. Press the "Save" button.

Now you can control all devices of this group with only one voice command. With the group function of the Alexa app, also different systems like Homematic IP and Philips Hue can be combined and controlled via voice command.

In the app, you can change the group name any time or add and delete devices with a tap on the group name. Furthermore, use the check boxes to assign or delete new devices.

-  When creating groups in the Alexa app, please make sure that only similar rooms and devices are allocated to one group (e.g. rooms for heating control or pluggable switches and switch actuators for controlling lights).
-  Commands for group functions are executed one after the other, not all at once.
-  When entering names, please make sure that they can be correctly assigned to avoid any confusion.

12.2.2 Alexa routines

With Alexa routines you can set up the digital assistant to start one or more actions in your smart home that you can define in the Alexa App with just only one voice command or alternatively at a defined time. Routines are not only limited to the control of smart home devices, but also a large number of Alexa functions and services can be integrated. For example, you can set up a "Good Morning routine" that allows you to start a variety of actions using just one voice command. You can create different routines according to your needs, for example for a perfect movie night. Or you can create a routine that turns off all the lights when you leave your home and activates the eco mode and absence mode for your home.

Routines can be easily set up via the Alexa App and can be deactivated and activated at any time according to your needs. The possibility to control not only individual devices via routines, but also already set up Alexa groups and scenes, makes creating routines even easier.

12.2.2.1 Creating routines

- Start the Alexa app and select „Routines“ from the main menu of the Alexa app.
- Tap on the „Plus“ symbol.
- Tap on „When this happens“. The following triggers are available in this menu:
 - "Voice" to start routines via voice command
 - "Schedule" for routines that you regularly want to activate at a certain time
 - "Device" to start routines via another Alexa device, like the Echo Plus
 - "Echo Button" to start routines via an Echo Button
- For example, tap „Voice“ and then enter the text for your voice command, such as „Good morning“.
- Tap on "Save".
- Tap on "Add action". In this menu item you can determine which actions are to be triggered.

Application example

In the menu item „Smart Home“ you will find Homematic IP devices and scenes that can be integrated into Alexa routines.

Action 1

- Tap on „Smart Home“ and then on „Control device“.
- For example, select „Bedroom light“. Tap the lamp icon to select whether to turn the light on or off. If the light is controlled via a dimming actuator, you also have the possibility to determine the brightness via a slider.
- Select „Switch on bedroom light“ and adjust the brightness to 50 %.
- Tap on "Continue".
- Tap on „Save“ to create and save the routine with the selected actions.

You can include further actions in your routine at any time. With the voice command „Alexa, good morning“ the light in the bedroom is now switched on and dimmed to 50%, the blinds are raised at the same time, the floor heating in the bathroom is switched on and the presence mode is deactivated. Alexa routines can also be extended by additional services. For example,

you can use music to wake up and have the current local weather report or the traffic situation on the way to your workplace read to you when you have the Alexa app completely configured.



The deactivation of the presence and absence mode via voice commands is only possible if the option „in every mode“ is set in the Homematic IP app under „Settings“, „Voice control“, „Control during active alarm mode“.

12.2.2.2 Deleting the connection between Homematic IP and Alexa

The connection between your Homematic IP app and the Alexa app can be deleted as follows:

- Open the Homematic IP app and in the menu, tap "Settings" in the "General" section.
- Select "User overview". In the next window, choose the "Amazon Alexa Client".
- With a swipe to the left (iOS) or long press on the name (Android) a window is opened for deleting the client. Tap on "Delete" (iOS) or the  icon (Android). The connection between Homematic IP and Amazon Alexa is deleted.

Open the Alexa app and deactivate the Homematic IP skill here:

- Open the left navigation area in the Alexa app and tap on "Smart Home".

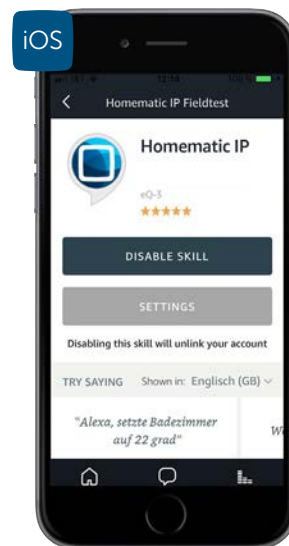

Figure 115: Screenshot deactivating the Homematic IP skill

- Tap on "Your skills" and choose "Homematic IP". Press the "Disable skill" button.

12.3 Voice control with Google Assistant/Home

12.3.1 Setting up Google Home

- Connect your Google Home-enabled loud speaker via the mains cable to the power supply.
- Download the free Google Home app to your smartphone.
- Open the Homematic IP app and tap in the main menu on “Settings”, “Voice control” and there select “Google Assistant/Home”.

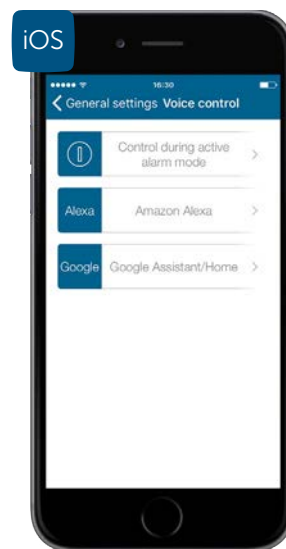

Figure 116: Screenshot main menu voice control

- In the next window, the activation key will be displayed.



Figure 117: Screenshot copying the activation key

- Tap on the  icon (Android) or “Copy” (iOS).

In the Google Home app, activate the connection to your Homematic IP installation:

- Start the Google Home app and follow the installation instructions. Log-in using the information of your Google account.
- After installation of your Google Home app, you will be directed to the homescreen. Tap on the main menu icon and there on "Home control".

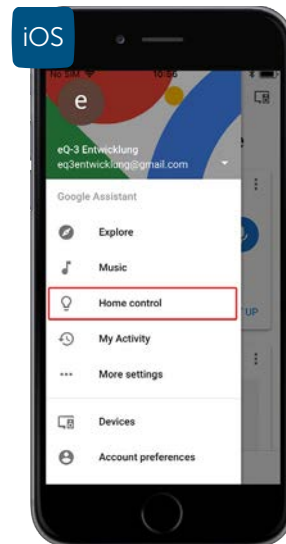

Figure 118: Screenshot Google Home main menu

- Tap in the next window on the + icon to add Homematic IP.

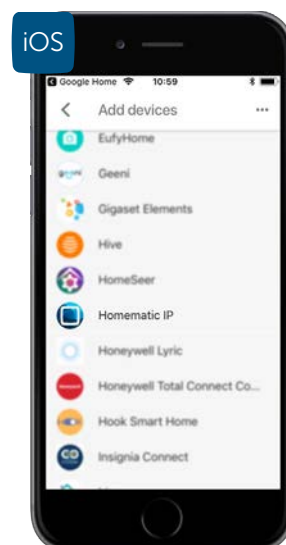

Figure 119: Screenshot Google Home app, adding Homematic IP

- Select "Homematic IP" from the overview.
- Under certain circumstances, you have to log-in with your account information again.
- In the next window you will have to enter the previously copied Homematic IP activation key.

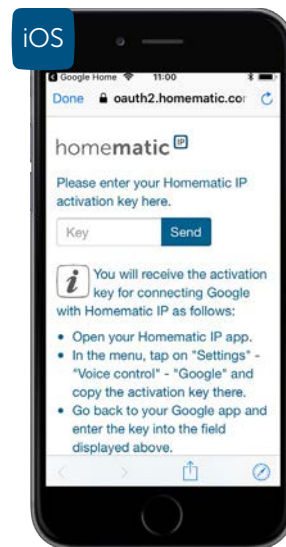

Figure 120: Screenshot entering the activation key

- Enter the activation key into the request field. Therefore, keep the entry field pressed and tap on "Enter".
- Press the "Send" button to establish the account linking.
- Your Homematic IP service will be connected with Google Home and all available devices are shown in the next window.

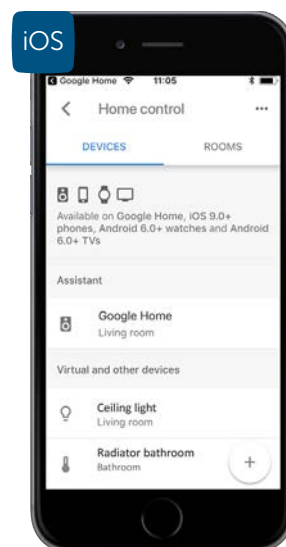

Figure 121: Screenshot devices overview

You will now be able to control a large number of functions and devices of your Homematic IP smart home system via voice control. First, assign the devices and functions to rooms, in order to make later allocation easier.

12.3.1.1 General information about Google and Homematic IP

Google-enabled devices only react to voice commands if you say the wake word "OK Google" or "Hey Google", e.g.:

"Ok Google, set bathroom to 29 degrees."

You should use unique names for all Homematic IP devices, functions and Homematic IP switching groups. Only in this way Google will be able to assign them correctly.

If voice commands are not executed correctly you can adjust device and group names in the Google Home app with the function "Set a nickname" or "Nickname", to optimize the detection and allocation of voice commands.

12.3.1.2 Voice command examples

Via switching actuators and switching groups defined in the Homematic IP app you can switch your devices on or off. You can use the activation phrase "Ok Google" or "Hey Google".

Example:

"Ok Google, turn on the bedroom light."

In the Google Home app, you can allocate several devices or switching groups to rooms and afterwards control all devices in a room via voice command, for example.

Example:

"Hey Google, turn on the living room lights."

Furthermore, lights can be set to a desired brightness value:

Example:

"Ok Google, set ceiling light in living room to 50 percent."

"Hey Google, increase the floor lamp in living room by 20 percent."

"Ok Google, decrease reading lamp in bedroom by 40 percent."

You can simultaneously switch on and off the switching groups that you have defined via the Homematic IP app as well as all groups of an installation, e.g. for light control.

Example:

"Hey Google, turn off all lights."

12.3.1.3 Devices and functions supported by Google

The following Homematic IP devices and functions are currently supported:

Device/function	On	Off	Set %	Raise %	Lower %	Set °C	Raise °C	Lower °C	Request values
Switching actuators	✓	✓							
Dimming actuators	✓	✓	✓	✓	✓				
Switching groups	✓	✓	✓						
Heating groups						✓	✓	✓	✓
Absence mode	✓								
Presence mode	✓								
Eco mode	✓	✓							

12.3.1.4 Google update of the device list

If you have changed names of devices or functions in the Homematic IP app or if you have connected new devices it is currently still necessary to disconnect the Homematic IP app from Google Home and to re-establish the connection again afterwards. This will be improved by Google in a future version.

- In the device overview, select “Manage accounts” in the top of the screen.

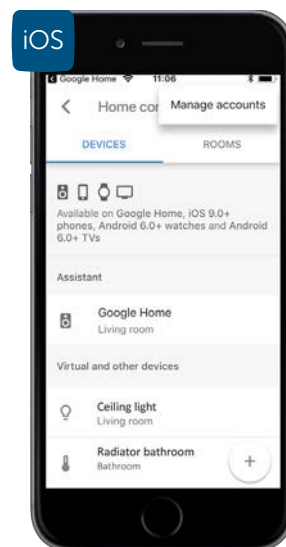

Figure 122: Screenshot managing accounts

- In the next step, choose the Homematic IP app and tap “Unlink account”.

Afterwards, link your Google Home and the Homematic IP app again as described above.

12.4 Voice control with Google Assistant

Similar to voice control in connection with the Google Home loud speaker, you can also use the voice control without loud speaker, only via the Google Assistant app. Setup is similar to Google Home.

- Download the free Google Assistant app to your smartphone.
- Log-in using your Google account.
- Tap in the menu on "Settings". In the "Services" section select "Home control". Here you can link your Homematic IP system with Google Assistant as described above.

After setup, you can use the voice control with your smartphone via Google Assistant to control your Homematic IP system using voice commands.

12.5 Voice control during active alarm mode

Due to security reasons, alarm functions can be activated but not deactivated via voice commands. The system is already configured in that way that voice command devices do not execute any commands for Homematic IP functions during activated absence mode or presence mode.

Via the app you can configure your system in that way that voice commands can still be executed for Homematic IP functions also during active presence mode or absence mode. To do this, proceed as follows:

- Open the Homematic IP app.
- Tap "Settings" in the menu and select the menu item "Voice control", "Control during active alarm mode".

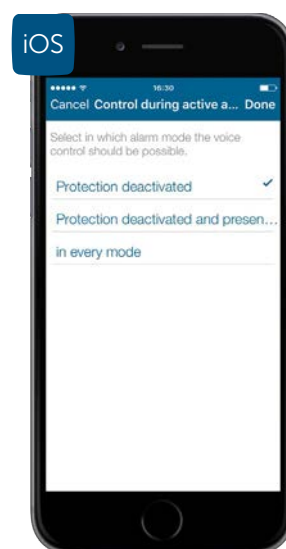

Figure 123: Screenshot selecting alarm mode for voice control

Here you can select between three options:

- **Protection deactivated:** When selecting this option, voice control is enabled only during active alarm mode "protection deactivated".
- **Protection deactivated and presence mode:** When selecting this option, voice control is enabled in alarm modes "protection deactivated" and "presence mode".
- **in every mode:** Voice control is enabled in each alarm mode.

13 INTEGRATION INTO HOMEMATIC SYSTEMS

With the Homematic WebUI user interface, all Homematic IP devices can be easily integrated into existing Homematic systems via the Homematic Central Control Unit CCU2/CCU3. In this way, Homematic and Homematic IP devices can be used with the CCU2/CCU3 at the same time.

After teaching-in Homematic IP devices to the CCU2/CCU3, configuration and operation of devices is done via the web based user interface "Homematic WebUI" on your PC, just like all other Homematic devices.

In this case, the data of connected Homematic IP devices is not saved in the Homematic IP cloud, but locally in the Homematic Central Control Unit. In this way, an active Internet connection is not required permanently.

Requirements

- Teaching-in of Homematic IP devices to the CCU2/CCU3 requires the CCU2/CCU3 software version 2.17.14 or higher. Therefore, please make sure via the home page of your Homematic WebUI if a new software version is available for your CCU2/CCU3.
- Homematic IP devices can be taught-in to the CCU2/CCU3 only in as-delivered status. Please restore the factory settings for Homematic IP devices that have been connected to the Access Point first, before teaching-in to the CCU2/CCU3. You will find further information in the user manual of the corresponding device.

Teaching-in of Homematic IP device to CCU2/CCU3

- Start the user interface "Homematic WebUI" on your computer. Just like for Homematic devices, teaching-in for Homematic IP devices to the CCU2/CCU3 is performed via the "Teach-in devices" button on the right-hand side of the screen.



Figure 124: Screenshot home page WebUI

- After clicking the button "Teach-in devices" the following window appears:

The screenshot shows a web interface titled "Teach-in devices" with a grid layout. The grid has three rows and two columns. The first row is for "Homematic" devices, the second for "Homematic Wired" devices, and the third for "Homematic IP" devices. Each row contains two columns of text and buttons. A magnifying glass is positioned over the "Teach-in HmIP device" button in the bottom-left cell of the grid. At the bottom of the interface, there are two buttons: "Back" and "Inbox (0)".

Figure 125: Pop-up window "Teaching-in devices" WebUI

At the bottom of the page, the user interface offers two teach-in variants for Homematic IP devices:

If your Homematic Central Control Unit is connected to the Internet, the option „**Teaching-in of Homematic IP device with active Internet connection**“ should be selected.

- Click on the "Teach-in HmIP device" button. The teach-in mode of the Homematic CCU2/CCU3 will be activated for 60 seconds. An information box shows how much teach-in time remains.
- Meanwhile, please activate the teach-in mode of the Homematic IP device you want to teach-in to the CCU2/CCU3 as well. Establish the power supply for your device. You will find further information about activating the teach-in mode in the user manual of the corresponding device.
- After a short time and successful teach-in, the newly taught-in device appears in the inbox of your software interface. Click on the button "Inbox" to get to the inbox.



Newly taught-in Homematic IP devices and the corresponding channels are ready for operation and configuration in the Homematic system only after they have been configured in the inbox. Configuration instructions for newly taught-in Homematic IP devices can be found in the current version of the Homematic WebUI Manual, available for download at www.eq-3.com.

For operation of your CCU2/CCU3 without Internet connection, please select the option **“Teaching-in of Homematic IP device without Internet connection”**.

- For teaching-in, enter the key (device key) and the SGTIN (individual device number) of the Homematic IP device that you want to connect to the CCU2/CCU3 into the corresponding field.



The key and the SGTIN can be found on the sticker supplied with the device. Please keep the sticker in safe place.

- Start the teach-in procedure by clicking on the button **“Teach-in HmIP device (local)”**.

After a short time and successful teach-in, the newly taught-in device appears in the inbox of your software interface. Click on the button **“Inbox”** to get to the inbox.



Figure 126: Pop-up window “Inbox” WebUI



Newly taught-in Homematic IP devices and the corresponding channels are ready for operation and configuration in the Homematic system only after they have been configured in the inbox. Configuration instructions for newly taught-in Homematic IP devices can be found in the current version of the Homematic WebUI Manual, available for down by clicking [here](#).

After connecting your Homematic IP devices to the Homematic WebUI, your devices can be conveniently

- controlled and configured as well as
- used in central control unit programs.



After integration of Homematic IP devices into the CCU2/CCU3, various configuration parameters for your HmIP devices are available via your Homematic WebUI.



Please note that direct device connections between Homematic and Homematic IP devices are not possible due to the different protocols.

14 APPENDIX

14.1 Function overview for active and inactive Internet connection

Set-up and control of the Homematic IP system is carried out via the free Homematic IP smartphone app in connection with the Homematic IP cloud service.

In comparison with other systems, Homematic IP actuators offer the benefit that cloud-dependent functions like heating or time profiles as well as the communication of single devices with each other remain functional also without active Internet or cloud connection thanks to an integrated memory of the devices. Cloud-dependent functions are all rules created with the "automation" function, shutter configurations like lockout protection, storm protection, heat protection or escape function as well as the integration of voice control. They are verified in the cloud and require active Internet and cloud connection at all times. It is recommended to connect Homematic IP devices via group functions, like light and shutter groups, for example. On the one hand, the radio traffic is reduced. On the other hand, the connections created via groups remain functional also without connection to the Internet.

When using voice command services like Amazon Alexa or Google, it is also recommended to use Homematic IP remote controls or push-buttons for controlling your devices to enable switching of your components also without active voice control.

The following list gives an overview of available functions with or without active Internet connection:

Climate control	With Internet connection	Without Internet connection
Change settings via the Homematic IP app	✓	X
Heating profile is active	✓	✓
Reduction of the room temperature by window contacts when opening windows	✓	✓
Transmission of room temperature settings from radiator thermostats or wall thermostats to devices in the room	✓	✓
Activation of eco mode via wall-mount remote control	✓	X
Activation of manual mode	✓	✓
Activation of boost function	✓	✓
Activation of party mode for one room	✓	X
Deactivation of child protection lock that was activated via app	✓	X
Security and alarms		
Change settings via the Homematic IP app	✓	X
Transmission of smoke alarm messages to all connected smoke alarms in the system	✓	✓
Changing the alarm status (absence mode, presence mode, not activated)	✓	✓
Switching coming home light via key-ring remote control	✓	✓
Alarm notification via app	✓	X
Alarm notification via alarm siren	✓	✓
Switching panic light	✓	✓
Switching alarm light	✓	X
Shutter control		
Change settings via the Homematic IP app	✓	X
Switching of shutter groups via a remote control or push-button	✓	✓
Executing time profiles for shutters and blinds	✓	✓
Shutter and blind functions lockout protection, storm protection, heat protection, escape function	✓	X
Light		
Change settings via the Homematic IP app	✓	X
Switching switching groups on and off via a remote control or push-button	✓	✓
Switching of switching groups via motion detectors	✓	✓
Dimming of dimming actuators via a button pair of a switching group	✓	✓
Executing time profiles for switching actuators	✓	✓

14.2 Troubleshooting check-list

We have created the following check-list to find out possible malfunctions and its troubleshooting based on a check-list.

Malfunctions	Check box
Internet connection For setup and operation of your Homematic IP system, active Internet connection between the Access Point and the Homematic IP cloud is required.	
Note: If the Homematic IP Access Point should not be able to connect to the Internet for a longer period of time, disconnect the device for more than 10 seconds from the power supply and try again.	
Have you verified if your Internet connection is working correctly?	<input type="checkbox"/>
Is the Access Point connected to the router using the supplied network cable?	<input type="checkbox"/>
Does the system button of your Access Point light permanently blue?	<input type="checkbox"/>
Power supply For all Homematic IP devices, correct power supply has to be established. In case of problems with single or several devices, please check the following:	
Is your Access Point plugged into a socket with the plug-in mains adapter?	<input type="checkbox"/>
Are all mains-operated Homematic IP devices plugged-in correctly?	<input type="checkbox"/>
Did you make sure, that the batteries of battery operated devices have been inserted the right way around?	<input type="checkbox"/>
Did you remove the insulation strip between the battery and the battery contact of the corresponding devices, e.g. window / door contacts or radiator thermostats?	<input type="checkbox"/>
Are all batteries working correctly?	<input type="checkbox"/>
Start-up To make sure that your Homematic IP system is working correctly, your Homematic IP Access Point and other components must be registered to the Homematic IP server first. Please check the following indications for incorrect or not (yet) performed registration:	
Does an error message appear in the app and did you follow the instructions for troubleshooting?	<input type="checkbox"/> -
The registration has not been finished successfully. For devices with display this is indicated by a flashing radio signal icon (📶). Did you remove all sources for radio interferences (see sec. „3.3 Wireless range“ on page 14)?	<input type="checkbox"/>

<p>The registration has not been finished successfully. For devices without display this is indicated by long red lighting of the device LED. Did you remove all sources for radio interferences (see sec. „3.3 Wireless range“ on page 14)?</p>	
<p>Reception problems In case of unfavourable locations for radio components (see sec. „3.3 Wireless range“ on page 14), reception problems may be caused by disturbed radio communication. Please check the following indications for reception problems:</p>	
<p>The radio signal has not been transferred successfully. For devices with display this is indicated by a flashing radio signal icon (📶). Did you remove all sources for radio interferences (see sec. „3.3 Wireless range“ on page 14)?</p>	
<p>The radio signal has not been transferred successfully. For devices without display this is indicated by long red lighting of the device LED. Did you remove all sources for radio interferences (see sec. „3.3 Wireless range“ on page 14)?</p>	
<p>Does an error message appear in the app and did you follow the instructions for troubleshooting?</p>	

Reception problems can be avoided from the very beginning if you verify the signal transmission quality with a test setup. Often, it is caused by building materials with high attenuation values. Also *active sources of interference* like microwave ovens and wireless phones close to radio components can influence on the radio communication. You will find further important information in chapter “3.3 Wireless range”.

14.3 Homematic IP radio protocol and receive modes

Bidirectional communication

The radio communication between Homematic IP devices is always performed in a bidirectional way. The receiver confirms each radio command that is sent and transfers to the transmitter that a command has been recognised and executed. Bidirectional communication offers increased reliability for each system. In addition, you are informed about the current state of the devices involved at any time (e.g. window or switching state) based on the feedback type.

Security

Already during installation of the system the communication of Homematic IP is secure and cannot be manipulated. Also during operation, encryption of radio data avoids that data packages are read unnoticed or manipulated. Radio commands are only executed if the authorisation control of the transmitter by the receiver (encrypted authentication) has been successful. Intercept, change or other attacks to the data are not possible.

For encryption and authentication, the encryption standard *AES-128* in CCM mode is used. This technology is considered to be very secure worldwide.

Optimising the battery operation

If Homematic IP devices are not directly triggered, they remain in "sleep mode" or stand-by-mode, which has positive influence on the battery consumption.

The system works with two different frequencies. For normal radio operation between Homematic IP devices, the 868.3 MHz band is used. Special functions like wake on radio ("waking" of battery operated devices), and updates of the device software update (OTAU) use an additional frequency (869.525 MHz) (see sec. „14.3.1 Device software update (OTAU)“ on page 200).

Range

The range of devices based on radio communication depends on numerous factors, especially in buildings. This is why radio signals can be attenuated by special local structures, high humidity, barriers like inappropriately positioned furniture or metal covered surfaces. These are called attenuation. For indicating the range of radio signals, the so called open area radio frequency has been established. It describes the range of radio signals in free field, without disturbing influences, and is between 150 m and 400 m for Homematic IP. Due to attenuation, the range is lower within buildings but in most cases it is enough to ensure reliable radio communication. This especially applies, if the instructions of chapter "3.3 Wireless range" are considered for positioning the radio components.

Receive modes

Homematic IP differentiates three different receive modes:

- **Always listening** is a mode in which the devices are listening permanently, i.e. they are ready to receive radio signals at any time. This is the case for all Homematic IP devices that are connected to the mains voltage. The low energy that is required for permanent reception of radio signals, plays a subordinated role in comparison to battery operated devices. Examples are pluggable switches and pluggable switch and meter.
- **Cyclical reception** describes a receive mode for mains voltage supplied devices,

where a radio connection is established at regular intervals. For instance, the Homematic IP Radiator Thermostat is changing to receiving mode on a regular basis, e.g. to recall the current temperature from the Homematic IP Wall Thermostat.

- Another receive mode, especially for battery operated Homematic IP devices is called **wake on radio**. In this case, the receiver is “woken up” to receive radio data. During the remaining time, the receiver stays in energy saving “sleeping mode”. Due to this function, e.g. the Homematic IP Window / Door Contact can immediately reduce the temperature of radiator thermostats, if an open window has been detected. If the signals are directed to another Homematic IP device, the receiver will go back to the energy saving “sleeping mode”.

During the development of Homematic IP, the wake on radio function of Homematic has been further improved. In Homematic, all devices “wake up” as soon as the radio communication is active on the 868.3 MHz band. For Homematic IP, this function has been moved to another frequency (869.525 MHz). However, devices that support wake on radio are woken up from “sleeping mode” only if this is really required. Another advantage is that this function does not influence on the *duty cycle limit* of the corresponding device.

All three methods are proven in millions of devices by eQ-3 and protected by patents, especially for battery operation.

14.3.1 Device software update (OTAU)

To keep your Homematic IP devices up to date, Homematic IP offers the opportunity to update the device software (firmware) of the components. The device firmware controls all functionalities of your Homematic IP devices. The OTAU method (Over The Air Update) is an especially comfortable method to provide new firmware to single devices, e.g. radiator thermostats, via radio communication.

In a Homematic IP solution, the device software updates are performed in the background (background OTAU). In the server (Homematic IP cloud) a device list with the relevant serial numbers and firmware versions is provided. If for one or more of your Homematic IP devices a new device software is available, the Homematic IP cloud forwards this information to your Homematic IP Access Point. This transfers with every send radio telegram one part of the new firmware file into the memory of the device.

14.3.2 Duty cycle

Like various other radio based devices, also Homematic IP components are subject to legal regulations regarding the transmission time of radio signals (*Duty cycle limit*). The aim of this regulation is to ensure a high level of transmission security of all devices working in a defined frequency range using the short transmission times. Homematic IP devices operate in the 868.3 MHz and 869.525 MHz frequencies. The second frequency is mainly used for wake on radio (see sec. „14.3 Homematic IP radio protocol and receive modes“ on page 199).

In the 868.3 MHz frequency range that is used for radio transmission of Homematic IP devices,

the maximum transmission time of any device is 1 %, i.e. 36 seconds in an hour. If this limit is exceeded, the corresponding device may transmit only after the maximum transmission time falls below the limit, for example after the hour expired.









The relatively low duty cycle value of 1 % offers the benefit that the radio channels are not continuously occupied due to the short transmission times. Thus, there is a very high security level at all times. This also has positive effect on the radio wave impact (see sec. „3.3 Wireless range“ on page 14).

During normal operation, the *duty cycle* is not usually reached. However, during setup or first installation of a system, repeated and wireless-intensive teach-in processes mean that the *duty cycle limit* can be exceeded. This is usually indicated by the device temporarily working incorrectly and the flashing code of the device LED, as further transmission by the devices is prevented. The devices start working correctly again after a short period (max. 1 hour).

14.3.3 Lazy config

Due to the 'lazy config' function, configuration of Homematic IP devices is particularly easy. If configuration data is changed in the app, the Homematic IP Access Point "remembers" the data. If the device is operated for the next time, e.g. when pushing a wall-mount remote control or – in case of an installed window / door contact – when opening a window, the data is transferred automatically. Manual operation of the system button is not required.

14.4 Overview flashing behaviour of Homematic IP devices

Flashing code	Meaning	Comment
 Short orange flashing (followed by green or red lighting)	Attempting to transmit, e.g. on button press of a remote control	Please wait, until transmission has been confirmed (long green lighting) If the LED lights up long red, the radio transmission failed.
 1 x long green lighting	Transmission confirmed	You can continue operation.
 1 x long red lighting	Transmission failed (e.g. device can not be accessed or duty cycle limit is reached)	Please try again later.
 Short orange lighting (after green or red confirmation)	Weak battery	Replace the batteries.
 Fast orange flashing	Configuration data is transmitted	Wait until the transmission is completed.
 Short orange flashing (every 10 seconds)	Teach-in mode active (for 3 minutes)	Teach-in the device.
 Long and short orange flashing (alternating)	Device software update (OTAU)	Wait until the update is completed.
 Fast orange flashing (after long button-press)	Stage before resetting to factory settings	To start reset, press and hold down the system button again until the LED starts flashing green. Short button press will cancel reset.
 6 x long red flashing	Device defective	Please see your app for error message or contact your retailer.

14.5 Glossary

AES-128	AES (Advanced Encryption Standard) is an established, globally valid standard for the encryption of important information. The number indicates the used length of keys in bit.
Absence mode	The security functions of all components of the security solution are activated.
Actual temperature	Shows the current temperature that is measured by the Homematic IP Wall Thermostats.
Always Listening	Receive mode in which the devices are listening permanently, i.e. they are ready to receive radio signals at any time. This is the case for all Homematic IP devices that are connected to the mains voltage.
Attenuation	Reduction of radio signals with different characteristics due to barriers within buildings, like walls and ceilings, depending on the passage angle, material thickness and used materials.
Automatic mode	Operating mode for regulation of the room temperature in accordance with the heating profiles defined in the Homematic IP app (unlike the eco mode).
Base temperature	The base temperature indicates which constant temperature is to be kept in the room when the heating profile is neither in a heating nor in a lowering phase.
Boost function	With the boost function, cool rooms can be heated within short by opening the heating valve. There will be a pleasant room temperature right away because of the radiated heat.
Cloud	Virtual storage space where different users can access data and programs after he or she has been authorised via an Internet browser or software, like the Homematic IP smartphone app for example.
CO (Change Over)	Changes between the operating mode heating or cooling. You can realise switching between heating and cooling via an external switch connected to the Multi IO Box.
Cyclical reception	Describes a receive mode for mains voltage supplied devices, where a radio connection is established at regular intervals.
Dehumidifier	The humidity can be influenced by the Multi IO Box. With the dehumidifier function, a threshold value can be defined for controlling a fan or dehumidifying device via the Multi IO Box.
Duty cycle limit	Limit for transmission time of radio devices defined by law to increase the security level.
Eco function	The eco function for floor heating actuators can be activated for each heating zone. In the standard settings, the eco temperature for heating is at 19 °C. In the standard settings, the eco temperature for cooling is at 23 °C. You can realise switching between auto and eco mode via an external clock connected to the Multi IO Box. This is not influenced by the operating mode of the wall thermostat.
Eco mode	Operating mode for short-time regulation of the room temperature for all or selected rooms, planned or permanently in order to save energy (unlike the auto mode).

Emergency operation	The valve opening duration is recalculated every 15 minutes. If the radio communication between the wall thermostat and the floor heating actuator fails for a longer period of time, e.g. if a battery is empty, all valve are controlled automatically. In the default settings, the valve is opened for 225 seconds (25 % for 15 minutes). If the radio communication is recovered the system changes back to normal operation.
Follow-up time	Output stays active, if there is no more heating/cooling demand.
Heating profile	With freely programmable heating profiles you can define individually tailored temperatures for each room at any time. You can define up to three heating profiles per room with up to six heating and cooling phases per day.
Humidity input	Only in cooling operation - if the input is active all zones stay closed and the pumps off. For signalling, the device LED of the Multi IO Box starts flashing or the drop/cooling symbol appears on the wall thermostat.
Interference	Failure in radio communication in which two or more radio waves superpose.
IPv6	The Internet protocol version 6 (IPv6) is the successor of the widespread Internet protocol IPv4 for transmission of data packages across different networks. Besides the extension of the address space, the new protocol offers a large number of technical improvements.
LAN	Abbreviation for Local Area Network, connecting network components within a household, e.g. offices, with each other.
Lazy Config	Function to make configuration of Homematic IP devices easier. If the configuration data of a certain device is changed in the app, the Homematic IP Access Point "remembers" the data. The data is transferred automatically as soon as the devices is operated the next time. Manual operation of the system button is not required.
Lead time	Output is switched with a delay, as long as there is no heating/cooling demand.
Load balancing	Controls the active valves via the PWM (pulse-width modulation) cycle and provides continuous flow of heating water.
Load collection	When selecting "Load collection", the heating zones are controlled collectively (if possible). This increases the possibility that the boiler is switched off at the end of a PWM (pulse-width modulation) cycle.
Message delay	Message delay for Homematic IP Window / Door Contacts provides delayed transmission of radio signals. This function is especially appropriate for installation of window contacts or terrace doors, that are used as door and window for ventilation at the same time. In this time, the temperature of radiators is not reduced.
Open-window function	If a window is open, e.g. during ventilation, the Homematic IP system automatically reduces the temperature to save heating energy and costs. In connection with Homematic IP Window / Door Contacts, opening is detected at the precise time for regulation. After closing the window, the Homematic IP Radiator Thermostat changes back into the previous mode. When changing into auto mode, the temperature is regulated according to the set temperature in the week program.
OTAU	'Over the Air Update': Comfortable method for device software updates via radio.
Powerline	Technology for transmission of data via existing lines.

Presence mode	The security functions of all devices that you have selected for the presence mode are activated.
Pump protection function	Activation of the pump every 14 days for 1 minute.
Pump, local	A pump is connected to heating zone 1. Thus, heating zone 1 can no longer be used for controlling a heating zone.
PWM cycle	Time for controlling the active valves. The cycle time is 15 minutes.
Router	Network device that connects several networks with each other. Collects status information about the network and uses the information to transfer data packages to the correct target.
Setpoint temperature	Defines the temperature to be set in a room.
Silent alarm	If the silent alarm is activated, the indoor siren and the alarm light will not be triggered. In case of alarm, the system does only send a push-notification to the app.
Sources of interference	Factors of electrical devices like wireless headphones, baby phones or similar devices that have negative effect on the signal quality of radio components.
Temperature limiter	Only in heating operation – if the input is active all zones stay closed and the pumps off. For indication the device LED of the Multi IO Box flashes.
Temperature offset	If the radiator is installed at a disadvantageous place (e.g. behind a curtain or cupboard), the temperature measured by the sensor may be different to the room's actual ambient temperature. If the thermostat is unable to compensate the difference, general adjustment using the temperature offset has to be made. The temperature offset can be set individually for all thermostats of each room in a range between +/- 3.5 °C.
Wake on radio	Receive mode especially for battery operated devices; the receiver is woken up from 'sleeping mode' to receive radio data. During the remaining time, the receiver stays in energy saving 'sleeping mode'.
Wired	Technology for data transmission in home automation where wired components are used that communicate with each other via cable in a BUS system.

Homematic IP is a brand of eQ-3 AG

eQ-3 AG
Maiburger Straße 29
26789 Leer, Germany
www.eQ-3.com
support@eQ-3.de

Phone: +49 491 600 8 600
Fax: +49 491 600 899 600

**Subject to technical changes without notice.
Errors and printing errors excepted.**

homematic 